

# LIK 8MER

# Dimplex

**Montage- und  
Gebrauchsanweisung**

Deutsch

**Installation and  
Operating Instructions**

English

**Instructions d'installation  
et d'utilisation**

Français

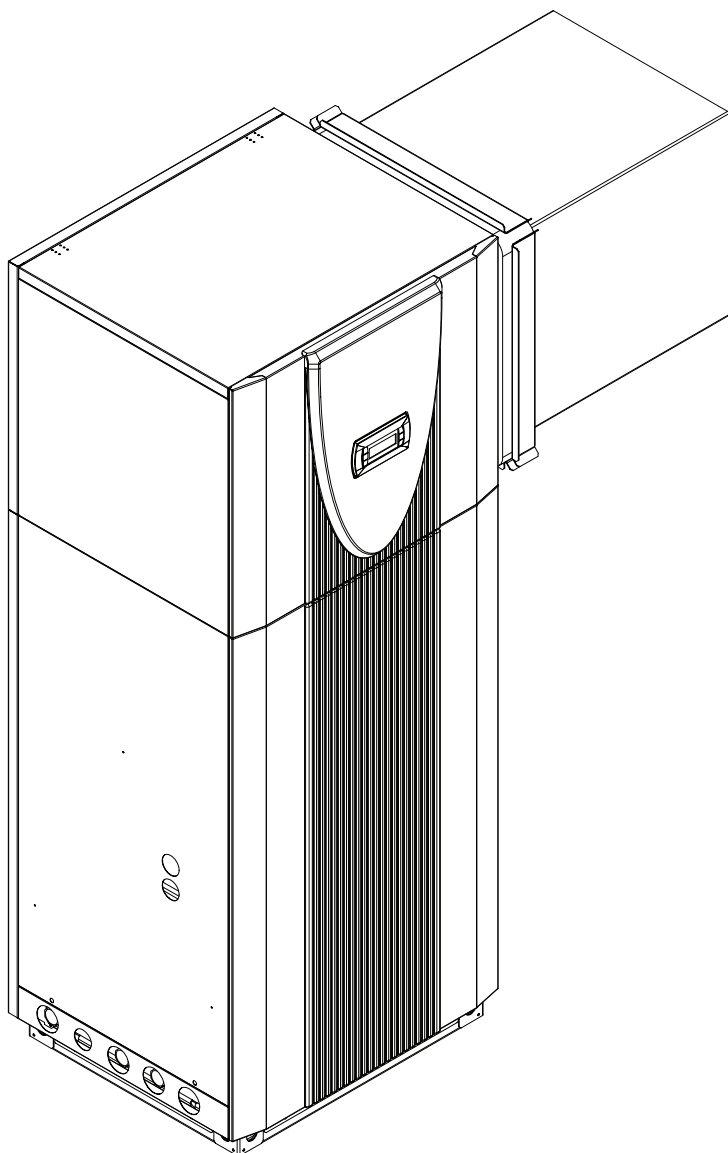

**Reversible  
Luft/Wasser-  
Wärmepumpe für  
Innenaufstellung**

**Reversible  
Air-to-Water  
Heat Pump for  
Indoor Installation**

**Pompe à chaleur  
air-eau réversible  
pour installation  
intérieure**

---

# Table of contents

<b>1</b>	<b>Please Read Immediately</b> .....	<b>E-2</b>
1.1	Important Information: .....	E-2
1.2	Legal Regulations and Directives .....	E-2
1.3	Energy-Efficient Use of the Heat Pump .....	E-2
<b>2</b>	<b>Purpose of the Heat Pump</b> .....	<b>E-3</b>
2.1	Application .....	E-3
2.2	Operating Principle .....	E-3
<b>3</b>	<b>Scope of Delivery</b> .....	<b>E-3</b>
3.1	Basic Device .....	E-3
3.2	Switch Box .....	E-4
3.3	Accessories Pack .....	E-4
<b>4</b>	<b>Transport</b> .....	<b>E-4</b>
<b>5</b>	<b>Set-UP</b> .....	<b>E-5</b>
5.1	General Information .....	E-5
5.2	Condensed Water Pipe .....	E-5
5.3	Sound .....	E-5
<b>6</b>	<b>Installation</b> .....	<b>E-5</b>
6.1	General Information .....	E-5
6.2	Air Connection .....	E-5
6.3	Heating System Connection .....	E-6
6.4	Electrical Connection .....	E-6
<b>7</b>	<b>Start-UP</b> .....	<b>E-7</b>
7.1	General Information .....	E-7
7.2	Preparation .....	E-7
7.3	Start-Up Procedure .....	E-7
<b>8</b>	<b>Maintenance / Cleaning</b> .....	<b>E-8</b>
8.1	Maintenance .....	E-8
8.2	Cleaning the Heating System .....	E-8
8.3	Cleaning the Air System .....	E-8
<b>9</b>	<b>Faults / Trouble-Shooting</b> .....	<b>E-8</b>
<b>10</b>	<b>Decommissioning/Disposal</b> .....	<b>E-8</b>
<b>11</b>	<b>Device Information</b> .....	<b>E-9</b>
	<b>Anhang / Appendix / Annexes</b> .....	<b>A-I</b>

# 1 Please Read Immediately

## 1.1 Important Information:

### **⚠ ATTENTION!**

The device is not suitable for operation with a frequency converter.

### **⚠ ATTENTION!**

When transporting the heat pump, ensure that it is not tilted more than 45° (in any direction).

### **⚠ ATTENTION!**

The heat pump and the wooden pallet are only joined by the packing film.

### **⚠ ATTENTION!**

Do not restrict or block the area around the air intake or outlet.

### **⚠ ATTENTION!**

In the case of large-volume heating circuits, an additional expansion vessel must be used to supplement the installed expansion vessel (24 litres, 1.0 bar admission pressure).

### **⚠ ATTENTION!**

Never use cleaning agents containing sand, soda, acid or chloride as these can damage the surfaces.

### **⚠ ATTENTION!**

We recommend the installation of a suitable corrosion protection system to prevent the formation of deposits (e.g. rust) in the condenser of the heat pump.

### **⚠ ATTENTION!**

Before opening the device, ensure that all circuits are isolated from the power supply.

### **⚠ ATTENTION!**

Work on the heat pump may only be carried out by authorised and qualified after-sales service technicians.

## 1.2 Legal Regulations and Directives

The construction and design of the heat pump complies with all relevant EU directives, DIN/VDE regulations (see CE declaration of conformity).

When connecting the heat pump to the power supply, the relevant VDE, EN and IEC standards are to be fulfilled. Any further connection requirements stipulated by local utility companies must also be observed.

When connecting the heating and/or cooling system, all applicable regulations must also be adhered to.

Persons, especially children, who are not capable of operating the device safely due to their physical, sensory or mental abilities or their inexperience or lack of knowledge, must not operate this device without supervision or instruction by the person in charge.

Children must be supervised to ensure that they do not play with the device.

## 1.3 Energy-Efficient Use of the Heat Pump

With the purchase of this heat pump you are helping to protect the environment. A prerequisite for energy-efficient operation is the correct design of the heat source system and heating (radiators and circulation pump) or cooling system.

It is particularly important for the efficiency of a heat pump to keep the temperature difference between heating water and heat source as small as possible. For this reason, it is advisable to design the heat source and heating system very carefully. **A temperature difference of approx. one Kelvin (1 °C) increases the power consumption by around 2.5 %.** When designing the heating system, it should be borne in mind that special consumers such as e.g. hot water preparation should also be considered and dimensioned for low temperatures. **Underfloor heating systems (panel heating)** are optimally suited for heat pump use on account of the low flow temperatures (30 °C to 40 °C).

It is important to ensure that the heat exchangers are not contaminated during operation because this increases the temperature difference, in turn reducing the COP.

Correct adjustment of the heat pump controller is also important for energy-efficient use of the heat pump. Further information can be found in the heat pump controller's operating instructions.

The heat pump is equipped with an **overflow mechanism** to prevent very low flow rates in the heat pump.

The installed buffer tank increases the amount of water in the heating circuit and guarantees reliable defrosting.

## 2 Purpose of the Heat Pump

### 2.1 Application

The air-to-water heat pump is designed for use in existing or newly built heating systems.

It is designed exclusively for heating and cooling heating water!

In heating operation, the heat pump is suitable for mono energy and bivalent operation down to an external temperature of -20 °C.

Proper defrosting of the evaporator is guaranteed by maintaining a heating water return flow temperature of more than 18 °C during continuous operation.

The heat pump is not designed for the increased heat consumption required when a building is being dried out. The additional heat consumption should be met using special devices provided by the customer. If a building is to be dried out in autumn or winter, we recommend installing an additional heating element (available as an accessory).

In cooling operation the heat pump is suitable for temperatures ranging from +15 °C to +40 °C.

It can be used for silent and dynamic cooling. The minimum water temperature is +7 °C.

#### **⚠ ATTENTION!**

The device is not suitable for operation with a frequency converter.

### 2.2 Operating Principle

#### Heating

Outside air is drawn in by the ventilator and fed via the evaporator (heat exchanger). The evaporator cools the air, i.e. it extracts heat from it. This extracted heat is then transferred to the working medium (refrigerant) in the evaporator.

The heat is "pumped" to a higher temperature level by increasing its pressure with the aid of an electrically driven compressor. It is then transferred to the heating water using the liquifier (heat exchanger).

Electrical energy is used to raise the temperature of the heat in the environment to a higher level. Because the energy extracted from the air is transferred to the heating water, this type of device is called an air-to-water heat pump.

The air-to-water heat pump consists of the main components evaporator, ventilator and expansion valve, as well as the low-noise compressor, liquifier and electrical control system.

At low ambient temperatures, humidity accumulates on the evaporator in the form of frost reducing the transfer of heat. The evaporator is defrosted automatically by the heat pump as required. Steam may be emitted from the air outlet depending on the atmospheric conditions.

#### Cooling

The functions of the evaporator and the liquifier are reversed in the "Cooling" operating mode.

The heating water transfers its heat to the refrigerant via the liquifier which is now functioning as an evaporator. The compressor raises the temperature level of the refrigerant and the heat is passed on to the surrounding air via the liquifier (functioning as an evaporator in heating operation).

## 3 Scope of Delivery

### 3.1 Basic Device

The compact heat pump is supplied complete with all of the important components of the heating circulation system:

- Expansion vessel
- Heat circulating pump
- Overflow valve and safety components (pressure relief valve, pressure gauge)

R404A is used as the refrigerant.

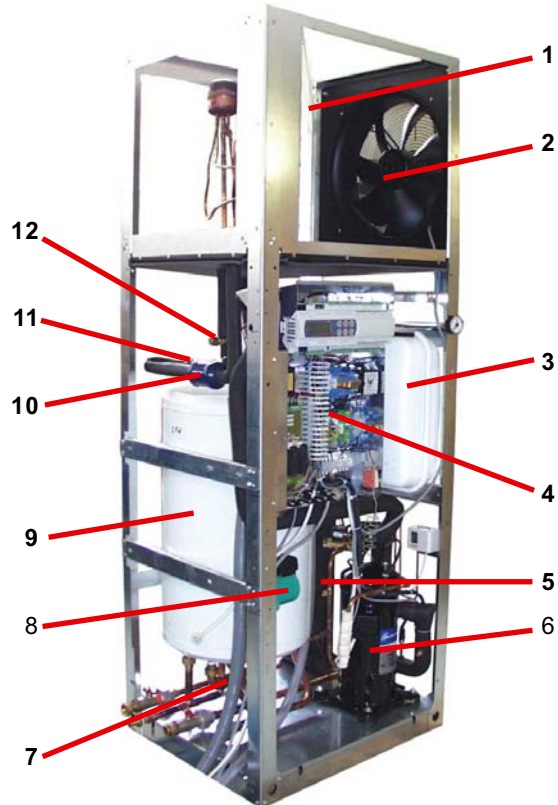

- 1) Evaporator (heating operation)
- 2) Ventilator
- 3) 24 l expansion vessel
- 4) Switch box
- 5) Liquifier (heating operation)
- 6) Compressor
- 7) Overflow valve
- 8) Heat circulating pump
- 9) Buffer tank
- 10) Filter dryer
- 11) Inspection window
- 12) Expansion valve

## 3.2 Switch Box

The switch box is located in the heat pump. It can be accessed by removing the lower front cover.

The switch box contains the supply connection terminals, as well as the power contactors, the soft starter unit and the heat pump manager.

The heat pump manager is a convenient electronic regulation and control device. It controls and monitors the entire heating or cooling system on the basis of the external temperature, including hot water preparation and safety systems.

The customer must install the external temperature sensor, which is included in the scope of supply of the heat pump controller together with the necessary fixing accessories.

The enclosed operating instructions describe the function and use of the heat pump manager.

## 3.3 Accessories Pack

### Contents:

- 2 Sealing rings for duct connection
- 3 1" connecting hoses
- 3 1" double nipples
- 6 1" flat gaskets
- 1 1" sealing plug
- 1 Hose nozzle for filling and drain cock
- 2 Fixing brackets
- 2 10-mm dowels
- 2 8 x 80 screws
- 4 M4 x 8 screws
- 1 External sensor
- 1 6-mm dowels
- 1 4.5 x 50 screws

## 4 Transport

### **! ATTENTION!**

When transporting the heat pump, ensure that it is not tilted more than 45° (in any direction).

Use a wooden pallet for transporting the heat pump to the final installation location. The basic device can be transported with a lift truck, hand truck or by means of 3/4" pipes fed through the holes in the base plate or frame.

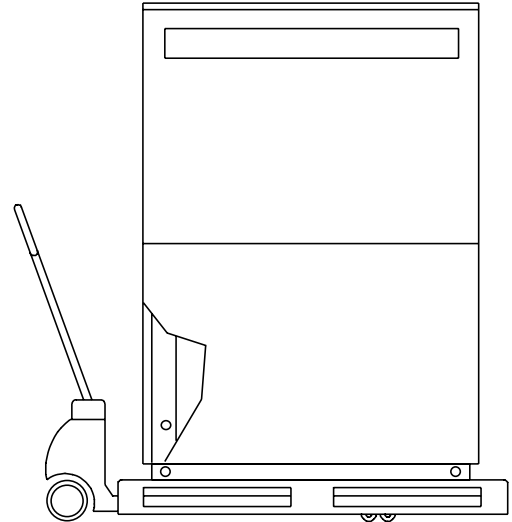

### **! ATTENTION!**

The heat pump and the wooden pallet are only joined by the packing film.

Before using the holes in the frame, it is advisable to remove each of the side panel assemblies. This is done by loosening each of the two screws at the base and then withdrawing the panels by unhooking them from above. Rehang the panels by gently pushing them in an upwards direction.

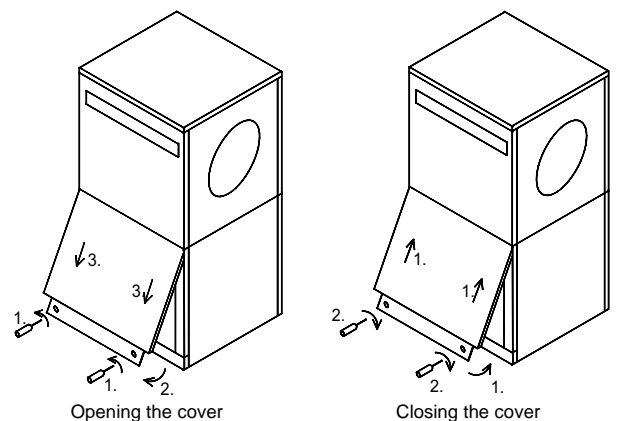

## 5 Set-UP

### 5.1 General Information

The heat pump is designed for installation in a corner. Other installation locations are also possible in combination with an air duct (available as an accessory) on the air outlet side.

The unit must be installed indoors on a level, smooth and horizontal surface. The entire base of the frame should lie directly on the floor to ensure a good soundproof seal. If this is not the case, additional sound insulation measures may be necessary.

The heat pump must be installed so that maintenance work can be carried out without being hindered. This can be ensured by maintaining a clearance of 1 m in front and to the left of the heat pump. **The side panel assemblies must not be covered by connecting pipes.**

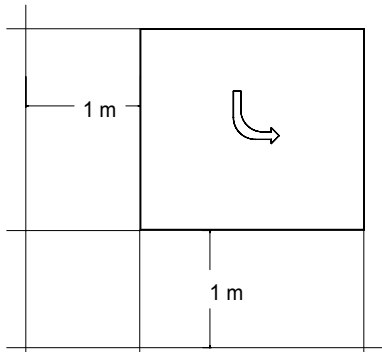

Never install the device in rooms subject to high humidity. Condensation can form on the heat pump and air circuit if the humidity exceeds 50 % and the external temperature is below 0 °C.

If the heat pump is installed on an upper storey, the load-bearing capacity of the ceiling should be checked. On account of the acoustics, measures for isolating possible vibrations should also be very carefully planned in advance as well. Installation on a wooden floor is not recommended.

### 5.2 Condensed Water Pipe

Condensed water that forms during operation must be drained off frost-free. The heat pump must be mounted on a level plane to guarantee proper drainage. The condensed water pipe must have a minimum diameter of 50 mm and should be fed frost-free into a sewer. Condensate should not be discharged directly into clearing tanks and cesspits because the aggressive vapours could destroy the evaporator.

### 5.3 Sound

To prevent solid-borne sound from being transmitted to the heating system, a vibration-damped connection should be used for connecting the heat pump with the heating system (install the supplied hose connections free of strain).

Installed air ducts should be sound-isolated from the heat pump to prevent the transmission of solid-borne sound to the ducts.

If both air openings are connected directly to a wall opening, the ventilator terminals can be reversed from a delta to a star connection (see information in the ventilator terminal box).

## 6 Installation

### 6.1 General Information

The following connections need to be established on the heat pump:

- Fresh and exhaust air
- Flow and return flow of the heating system
- Condensate outflow
- Outflow for the pressure relief valve
- Power supply

### 6.2 Air Connection

#### **⚠ ATTENTION!**

**Do not restrict or block the area around the air intake or outlet.**

The air intake opening of the device is solely designed for direct connection to a wall opening. The wall opening can be provided with air duct and sealing collar for this purpose. See the illustration in the appendix under Installation Dimensions.

The glass fibre reinforced concrete air ducts offered as accessories are moisture-resistant and diffusion-free.

The sealing collar is used to seal the air ducts on the heat pump. The air ducts are not screwed directly onto the heat pump. Only the rubber seal comes into direct contact with the heat pump when the system is installed correctly. This guarantees easy assembly and disassembly of the heat pump and also ensures that solid-borne sound is well insulated.

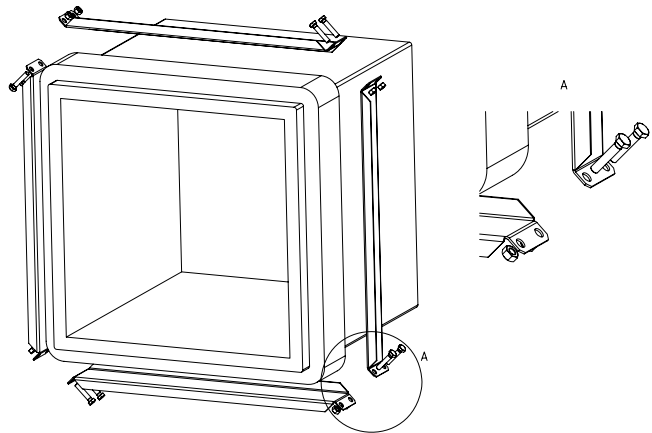

It must also be ensured that the interior side of the wall opening is lined with thermal insulation to prevent the wall from becoming cold and to prevent moisture from penetrating the wall. The enclosed fixing accessories can be used for attachment to the wall.

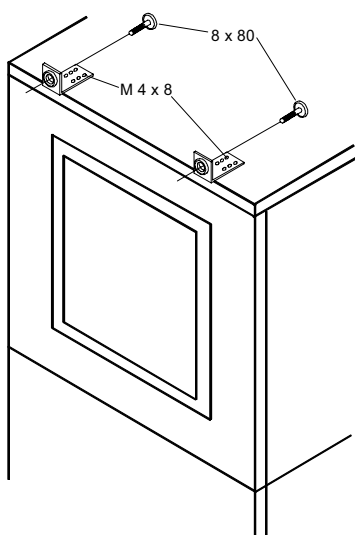

The air outlet can be optionally mounted directly to a wall opening or to a longer duct (available as an accessory). Use the same mounting procedure as for the air inlet.

If a flange-mounted air duct is used on the air outlet side, it is secured with 4 M8 x 16 hexagon bolts in the threaded holes provided. When doing this, ensure that the air duct stubs only touch the insulation. There should be no contact with the external sheeting.

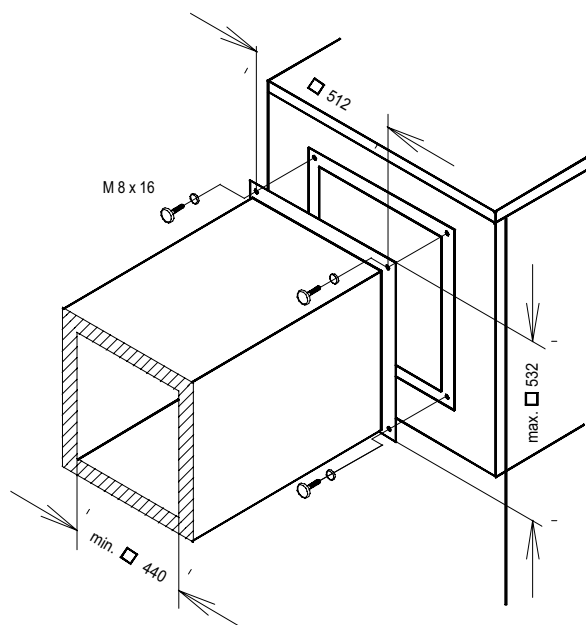

Observe the external and internal dimensions as specified in the figure. Also ensure that the vibration and duct isolation are adequate.

### 6.3 Heating System Connection

To enable connection to the heating system, flexible hose connection pieces and double nipples with a 1" external thread are included with the heat pump. These allow the optional use of a threaded or flat gasket connection to the heating system.

If the heat pump is not intended to be used to heat up the hot water, the hot water output must be permanently sealed using the supplied sealing plug.

Before connecting the heating water system to the heat pump, the heating system must be flushed to remove any impurities, residue from sealants, etc. Any accumulation of deposits in the liquifier could cause the heat pump to completely break down.

An overflow valve is installed in the device for systems in which the heating water flow can be shut off via the radiator or thermostat valves. This ensures a minimum heating water flow rate through the heat pump and helps to avoid faults.

Once the heating system has been installed, it must be filled, de-aerated and pressure-tested.

The integrated expansion vessel has a volume of 24 litres. This volume is suitable for buildings with a living space area to be heated of maximum 200 m<sup>2</sup>.

The volume should be checked by the heating system engineer. If necessary, an additional expansion vessel must be installed (according to DIN 4751, Part 1). The tables listed in the manufacturers' catalogues simplify dimensioning the system on the basis of the water content. Allow for a buffer tank volume of 80 litres when making the calculation.

#### **ATTENTION!**

In the case of large-volume heating circuits, an additional expansion vessel must be used to supplement the installed expansion vessel (24 litres, 1.0 bar admission pressure).

#### Antifreeze

A method of manual drainage (see illustration) should be provided for heat pumps which are exposed to frost. The antifreeze function of the heat pump controller is active whenever the controller and the heat circulating pumps are ready for operation. If the heat pump is taken out of service or in the event of a power failure, the system has to be drained. The heating circuit should be operated with a suitable antifreeze if heat pump systems are implemented in buildings where a power failure can not be detected (holiday home).

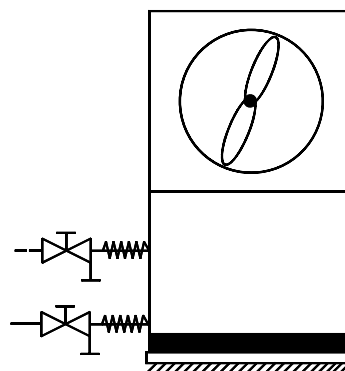

### 6.4 Electrical Connection

The power supply and control voltage are supplied using standard cables (load: 3-core, control: 3-core).

A disconnecting device with a contact gap of at least 3 mm (e.g. utility blocking contactor or power contactor) as well as a 1-pole circuit breaker must be installed in the power supply by the customer (tripping current in compliance with the Device Information).

The control voltage must be protected by a 10 A fuse. See Appendix Circuit Diagrams for detailed information.

## 7 Start-UP

### 7.1 General Information

To ensure that start-up is performed correctly, it should only be carried out by an after-sales service technician authorised by the manufacturer. This may be a condition for extending the guarantee (see Warranty Service). Start-up should be carried out in heating operation.

### 7.2 Preparation

The following items need to be checked prior to start-up:

- All of the heat pump connections must be established as described in Chapter 6.
- All valves that could impair the proper flow of the heating water in the heating circuit must be open.
- The air intake and air outlet paths must be clear.
- The ventilator must turn in the direction indicated by the arrow.
- The heat pump controller must be adapted to the heating system in accordance with the controller's operating instructions.
- Ensure the condensate outflow functions.
- The outflow from the heating water pressure relief valve must also function correctly.
- De-aeration of the heating system:  
Ensure that all heating circuits are open and the heat circulating pump is operating (level III).  
Connect the voltage to the heat pump controller. Select the heat generator 2 operating mode and de-aerate the system at its highest point. Top up with water if required (maintain static minimum pressure).

### 7.3 Start-Up Procedure

The heat pump is started up via the heat pump controller. Adjustments should be made in compliance with the instructions.

The performance level of the circulating pump must be adapted to the respective heating system.

The overflow valve must be adjusted to the requirements of the respective heating system. Incorrect adjustment can lead to faulty operation and increased energy consumption. We recommend carrying out the following procedure to correctly adjust the overflow valve:

Close all of the heating circuits that may also be closed during operation (depending on the type of heat pump usage) so that the most unfavourable operating state - with respect to the water flow rate - is achieved. This normally means the heating circuits of the rooms on the south and west sides of the building. At least one heating circuit must remain open (e.g. bathroom).

The overflow valve should be opened far enough to produce the maximum temperature spread between the heating flow and return flow listed in the following table for the current heat source temperature. The temperature spread should be measured as close as possible to the heat pump. The heating element of mono energy systems should be disconnected.

Heat source temperature		Max. temperature spread between heating flow and return flow
From	To	
-20 °C	-15 °C	4 K
-14 °C	-10 °C	5 K
-9 °C	-5 °C	6 K
-4 °C	0 °C	7 K
1 °C	5 °C	8 K
6 °C	10 °C	9 K
11 °C	15 °C	10 K
16 °C	20 °C	11 K
21 °C	25 °C	12 K
26 °C	30 °C	13 K
31 °C	35 °C	14 K

Any faults occurring during operation are also displayed on the heat pump controller and can be corrected as described in the operating instructions of the heat pump controller.

For external temperatures below 10 °C and heating water temperatures below 16 °C, the buffer tank should be heated up with the 2nd heat generator to at least 25 °C.

Observe the following procedure to implement a smooth start-up:

- 1) Close all of the heating circuits.
- 2) Fully open the overflow valve.
- 3) Use the controller to select the automatic operating mode.
- 4) Wait until the buffer tank has reached a temperature of at least 25 °C.
- 5) Now slowly reopen the heating circuit valves in succession so that the heating water throughput is constantly raised by slightly opening the respective heating circuit. The heating water temperature in the buffer tank must not be allowed to drop below 20 °C during this process. This ensures that the heat pump can be defrosted at any time.
- 6) Set the minimum volume flow quantity on the overflow valve and heat circulating pump when all heating circuits are fully open and a heating water temperature in the buffer tank of approx. 20 °C is maintained.
- 7) New buildings have an increased heat consumption on account of the energy required to dry them out. This increased heat consumption means that marginally dimensioned heating systems can not always achieve the desired room temperature. In such cases, we recommend keeping a 2nd heat generator on standby during the first heating period. The limit temperature on the heat pump controller should also be turned up to 15 °C.

## 8 Maintenance / Cleaning

### 8.1 Maintenance

To protect the paintwork, avoid leaning or putting objects on the device. External heat pump parts can be wiped with a damp cloth and domestic cleaner.

#### **⚠ ATTENTION!**

Never use cleaning agents containing sand, soda, acid or chloride as these can damage the surfaces.

To prevent faults due to sediment in the heat exchanger of the heat pump, ensure that the heat exchanger in the heating system can not be contaminated. We recommend protecting the evaporator by installing a bird guard in the inlet duct. At least 80 % of the cross section of the grating should be open. In the event that operating malfunctions due to contamination still occur, the system should be cleaned as described below.

### 8.2 Cleaning the Heating System

The ingress of oxygen into the heating water circuit may result in the formation of oxidation products (rust), particularly if steel components are used. These products enter the heating system via the valves, the circulating pumps and/or plastic pipes. It is therefore essential - in particular with respect to the piping of underfloor heating systems - that only diffusion-proof materials are used.

#### **⚠ ATTENTION!**

We recommend the installation of a suitable corrosion protection system to prevent the formation of deposits (e.g. rust) in the condenser of the heat pump.

Residue from lubricants and sealants may also contaminate the heating water.

In the case of severe contamination leading to a reduction in the performance of the liquifier in the heat pump, the system must be cleaned by a heating technician.

According to today's state of knowledge, we recommend using a 5 % phosphoric acid solution for cleaning purposes. However, if cleaning needs to be performed more frequently, a 5 % formic acid solution should be used.

In either case, the cleaning fluid should be at room temperature. We recommend flushing the heat exchanger in the direction opposite to the normal flow direction.

To prevent acidic cleaning agents from entering the heating system circuit, we recommend connecting the flushing device directly to the flow and return flow of the liquifier of the heat pump.

It is important that the system be thoroughly flushed using appropriate neutralising agents to prevent any damage from being caused by cleaning agent residue remaining in the system.

Acids must be used with great care and all relevant regulations of the employers' liability insurance associations must be adhered to.

If in doubt, contact the manufacturer of the chemicals!

The buffer tank is drained using the filling and drain cocks on the lower left of the device. Also open the ball valve on the pressure expansion vessel to vent the buffer tank.

### 8.3 Cleaning the Air System

Air ducts, evaporator, ventilator and condensate outflow should be cleaned of contamination (leaves, twigs, etc.) before the heating period. Do this by opening the left and front sides of the heat pump. The bottom should be opened first followed by the top.

#### **⚠ ATTENTION!**

Before opening the device, ensure that all circuits are isolated from the power supply.

Remove and rehang the side panel assemblies as described in Chapter 4.

To prevent the evaporator and the condensate tray from being damaged, do not use hard or sharp objects for cleaning.

## 9 Faults / Trouble-Shooting

This heat pump is a quality product and is designed for trouble-free and maintenance-free operation. In the event that a fault should occur, it will be shown on the heat pump manager display. Simply consult the Faults and Trouble-shooting page in the operating instructions of the heat pump manager. If you cannot correct the fault yourself, please contact your after-sales service technician.

#### **⚠ ATTENTION!**

Work on the heat pump may only be carried out by authorised and qualified after-sales service technicians.

## 10 Decommissioning/ Disposal

Before removing the heat pump, disconnect it from the power source and close all valves. Observe all environmentally-relevant requirements regarding the recovery, recycling and disposal of materials and components in accordance with all applicable standards. Particular attention should be paid to the proper disposal of refrigerants and refrigeration oils.

## 11 Device Information

<b>1 Type and order code</b>	LIK 8MER	
<b>2 Design</b>		
2.1 Model	Compact	
2.2 Degree of protection according to EN 60 529 for compact devices and heating components	IP 20	
2.3 Installation location	Indoors	
<b>3 Performance data</b>		
3.1 Operating temperature limits:		
Heating water flow/return flow	°C / °C	
Cooling, flow	°C	
Air (heating)	°C	
Air (cooling)	°C	
	Up to 58 / above 18	
	+7 to +20	
	-25 to +35	
	+15 to +40	
3.2 Temperature spread of heating water at A7 / W35	10.0	5.0
3.3 Heat output / COP		
at A-7 / W35 <sup>1</sup>	kW / ---	5.8 / 2.7
at A-7 / W45 <sup>1</sup>	kW / ---	5.5 / 2.6
at A2 / W35 <sup>1</sup>	kW / ---	5.4 / 2.1
at A7 / W35 <sup>1</sup>	kW / ---	7.5 / 3.3
at A7 / W45 <sup>1</sup>	kW / ---	7.4 / 3.2
at A10 / W35 <sup>1</sup>	kW / ---	9.3 / 3.9
		9.2 / 3.8
		8.8 / 3.2
		9.7 / 4.0
3.4 Temperature spread of cooling water at A35 / W7	7.5	5.0
3.5 Cooling capacity / COP		
at A27 / W7	kW / ---	7.9 / 2.7
at A27 / W18	kW / ---	7.9 / 2.6
at A35 / W7	kW / ---	9.6 / 3.2
at A35 / W18	kW / ---	9.6 / 3.2
		7.0 / 2.0
		6.9 / 2.0
		8.5 / 2.4
		8.5 / 2.4
3.6 Sound power level device / outdoors	dB(A)	
3.7 Sound pressure level at a distance of 1 m (indoors)	dB(A)	
	53 / 60	
	48.0	
3.8 Heating water flow with an internal pressure differential of <sup>2</sup>	m <sup>3</sup> /h / Pa	
	0.8 / 2700	1.6 / 11900
3.9 Free pressure, heating circulating pump (heating, max. stage)Pa	45000	
	27000	
3.10 Cooling water flow with an internal pressure differential of m <sup>3</sup> /h / Pa	0.8 / 2700	
	1.2 / 6500	
3.11 Free pressure, circulating pump (cooling, max. stage) Pa	45000	
	37000	
3.12 Air flow rate with an external static pressure differential of m <sup>3</sup> /h / Pa	2500 / 20	
3.13 Refrigerant; total filling weight	type / kg	
	R404A / 3.3	
3.14 Output of electric heating element (second heat generator)kW	2.0	
<b>4 Dimensions, connections and weight</b>		
4.1 Device dimensions	H x W x L cm	
	190 x 75 x 68	
4.2 Device connections to heating system	Inch	
	G 1" external	
4.3 Air duct inlet and outlet (min. internal dimensions)	L x W cm	
	44 x 44	
4.4 Weight of the transportable unit(s) incl. packing	kg	
	250	
4.5 Buffer tank volume	l	
	50	
4.6 Buffer tank pressure rating	bar	
	6	
<b>5 Electrical Connection</b>		
5.1 Nominal voltage; fuse protection	V / A	
	230 / 20	
5.2 Nominal power consumption <sup>1</sup> A2 W35	kW	
	2.27	2.33
5.3 Starting current with soft starter	A	
	30	
5.4 Nominal current A2 W35 / cos φ	A / ---	
	12.3 / 0.8	12.7 / 0.8
<b>6 Complies with the European safety regulations</b>	3	
<b>7 Additional model features</b>		
7.1 Defrosting	Automatic	
Type of defrosting	Reverse cycle	
Defrosting tray included	Yes (heated)	
7.2 Heating water in device protected against freezing <sup>4</sup>	Yes	
7.3 Performance levels	1	
7.4 Controller internal/external	Internal	

1. This data indicates the size and capacity of the system. For an analysis of the economic and energy efficiency of the system, other parameters, such as, in particular, the defrosting capacity, the bivalence point and regulation, should also be taken into consideration. The specified values, e.g. A2 / W55, have the following meaning: External temperature 2 °C and heating water flow temperature 55 °C.

2. The heat circulating pump is integrated.

3. See CE declaration of conformity

4. The heat circulating pump and the heat pump controller must always be ready for operation.

---

## Anhang / Appendix / Annexes

<b>1</b>	<b>Maßbilder / Dimension Drawings / Schémas cotés</b> .....	<b>A-II</b>
1.1	Wärmepumpe / Heat pump / Pompe à chaleur .....	A-II
1.2	Einbaumaße / Installation Dimensions / Cotes de montage .....	A-III
<b>2</b>	<b>Diagramme / Diagrams / Diagrammes</b> .....	<b>A-IV</b>
2.1	Heizbetrieb / Heating Operation / Mode chauffage.....	A-IV
2.2	Kühlbetrieb / Cooling Operation / Mode refroidissement .....	A-V
<b>3</b>	<b>Stromlaufpläne / Circuit Diagrams / Schémas électriques</b> .....	<b>A-VI</b>
3.1	Steuerung Standardregler / Control of the standard controller / Commande régulateur standard .....	A-VI
3.2	Steuerung Kühlregler / Control of the cooling controller / Commande régulateur standard .....	A-VII
3.3	Last / Load / Charge .....	A-VIII
3.4	Anschlussplan Standardregler / Terminal diagram for the standard controller / Schéma électrique du régulateur standard.....	A-IX
3.5	Anschlussplan Kühlregler / Terminal diagram for the cooling controller / Schéma électrique du régulateur refroidissement .....	A-X
3.6	Legende / Legend / Légende.....	A-XI
<b>4</b>	<b>Hydraulisches Prinzipschema / Hydraulic Plumbing Diagram / Schéma hydraulique</b> .....	<b>A-XIII</b>
4.1	Darstellung / Schematic view / Représentation .....	A-XIII
4.2	Legende / Legend / Légende.....	A-XIV
<b>5</b>	<b>Konformitätserklärung / Declaration of Conformity / Déclaration de conformité</b> .....	<b>A-XV</b>

# 1 Maßbilder / Dimension Drawings / Schémas cotés

## 1.1 Wärmepumpe / Heat pump / Pompe à chaleur

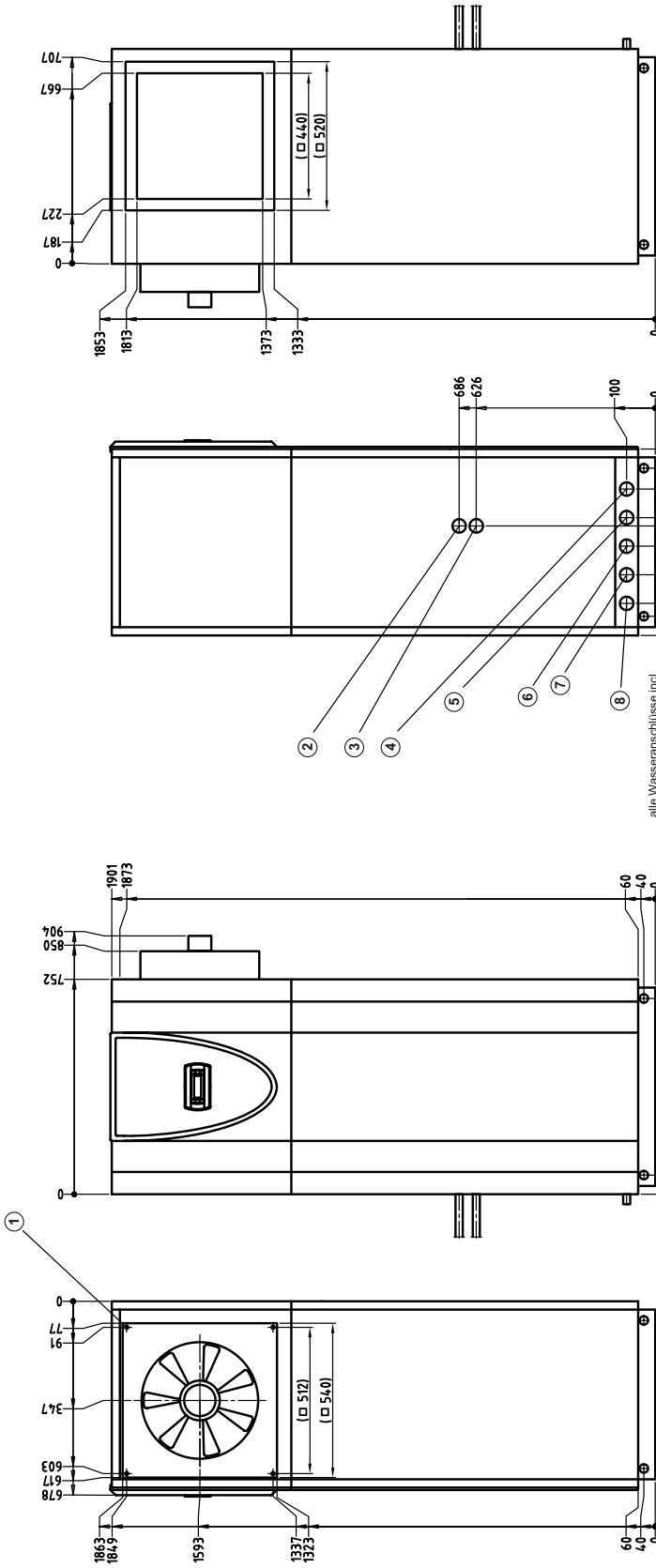

alle Wasseranschlüsse incl. 500 mm Schlauch und Doppel-nippel (beides beliebig)  
 All water connections, incl. 500 mm hose and double nipple. (included in the scope of supply)  
 Tous les raccords d'eau, y compris tuyau de 500 mm et rippe double (les deux sont joints)

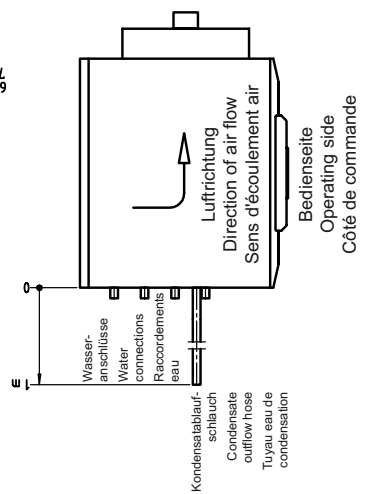

1	4x Innengewinde M8x15	4 x internal thread M8 x 15	4x filetage intérieur M8x15
2	Kondensatablauf innen ø 30 mm	Condensate outflow inside ø 30 mm	Écoulement du condensat ø int. 30 mm
3	Überdruck Heizkreis innen ø 19 mm	Overpressure heating circuit internal ø 19 mm	Surpression circuit de chauffage intérieur ø 19 mm
4	Elektroleitungen	Electric lines	Lignes électriques
5	Heizungsvorlauf Ausgang aus der WP 1" Innen-/Außengewinde	Heating water flow Heat pump outlet 1" internal/external thread	Aller eau de chauffage Sortie de la PAC Filetage intérieur/extérieur 1"
6	gemeinsamer Rücklauf Eingang in die WP 1" Innen-/Außengewinde	Common return flow Heat pump inlet 1" internal and external threads	Reflux commun Entrée dans la PAC Filetages int./ext. 1"
7	Füll- und Entleerungshahn	Feed and drain tap	Robinet de remplissage et de vidage
8	Warmwasservorlauf Ausgang aus der WP 1" Innen-/Außengewinde	Hot water flow Heat pump outlet 1" internal / external thread	Départ eau chaude Sortie de la PAC Filetage int./ext. 1"



## 2 Diagramme / Diagrams / Diagrammes

### 2.1 Heizbetrieb / Heating Operation / Mode chauffage

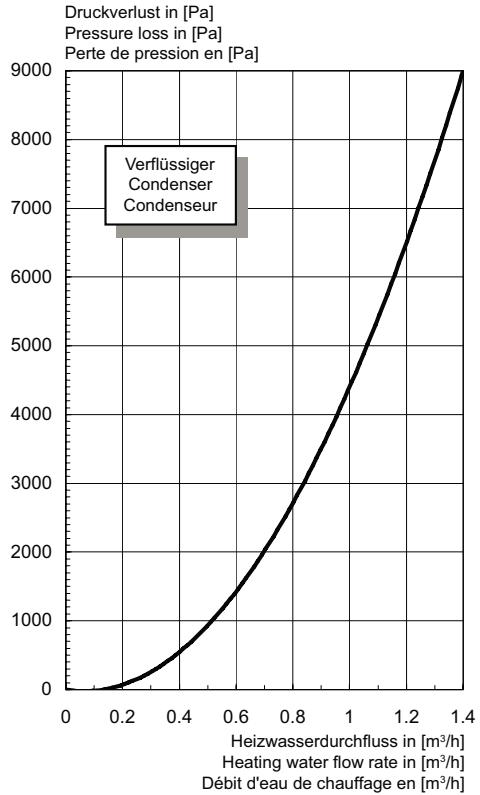
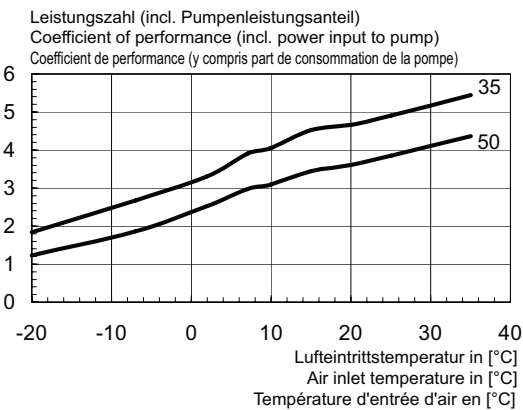
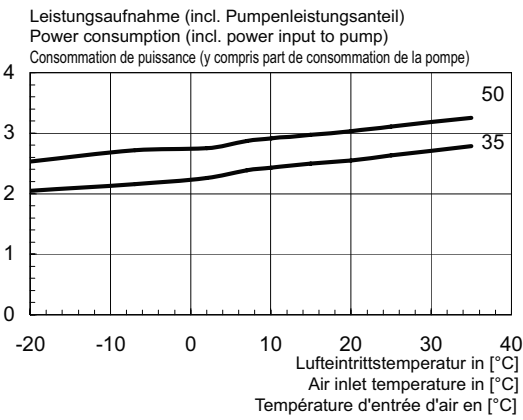
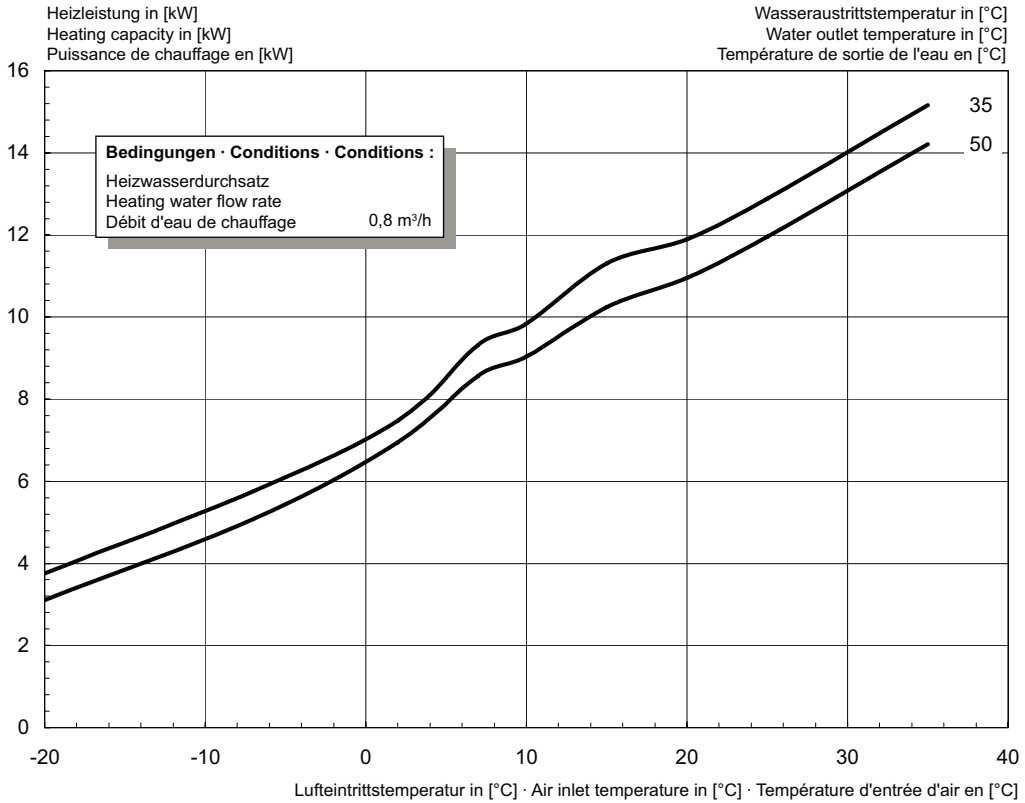

Anhang · Appendix · Annexes

## 2.2 Kühlbetrieb / Cooling Operation / Mode refroidissement

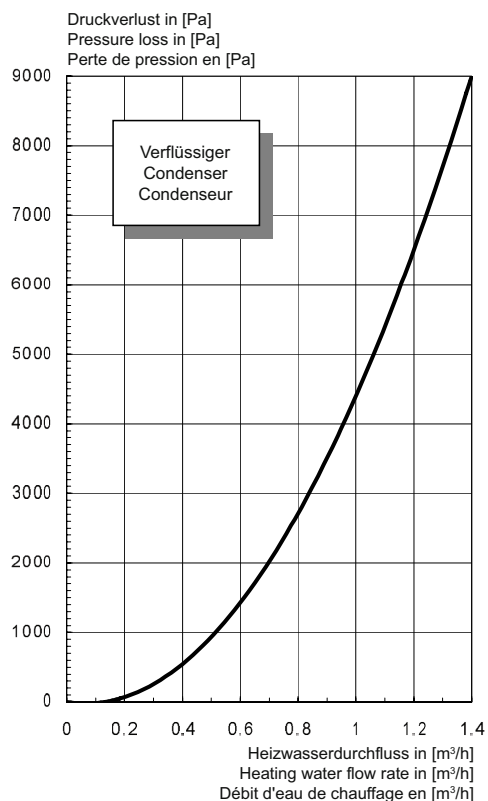
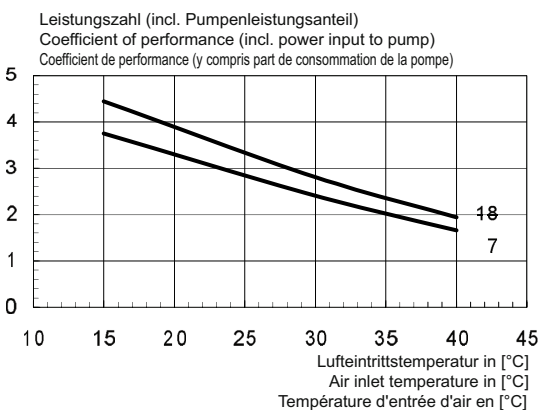
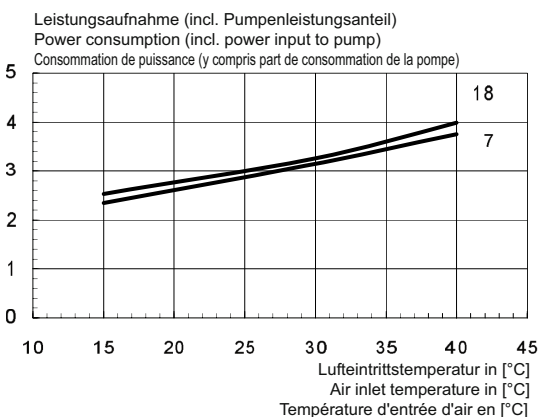
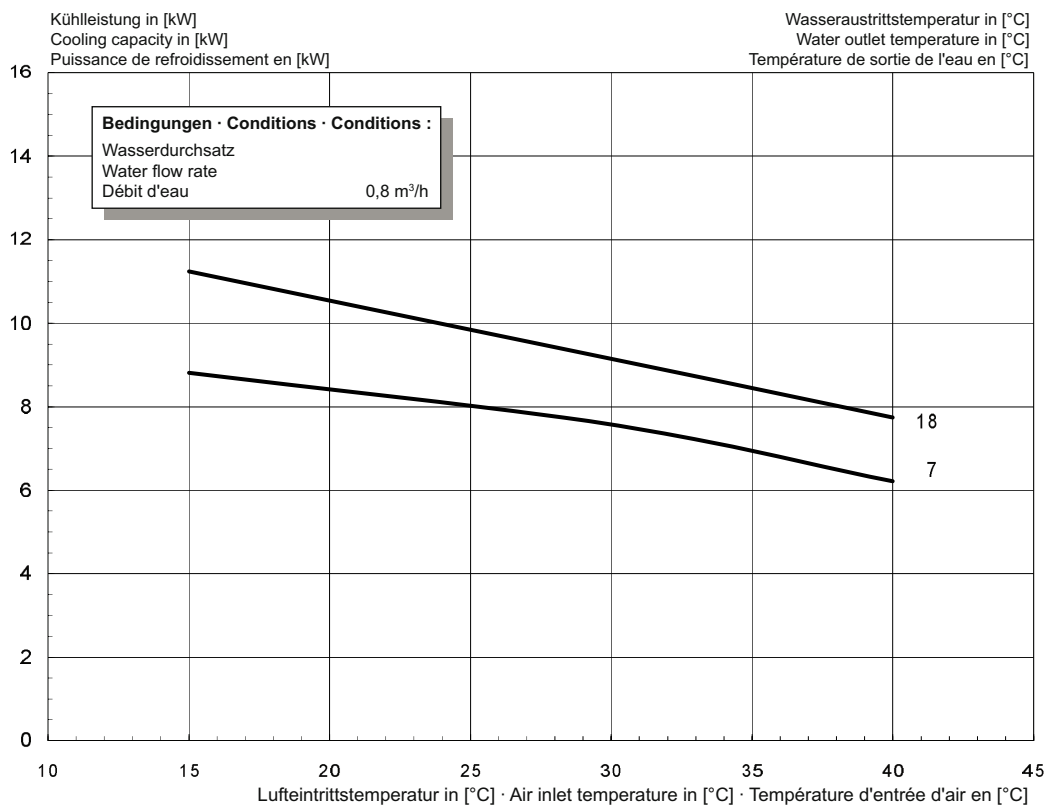

### 3 Stromlaufpläne / Circuit Diagrams / Schémas électriques

#### 3.1 Steuerung Standardregler / Control of the standard controller / Commande régulateur standard

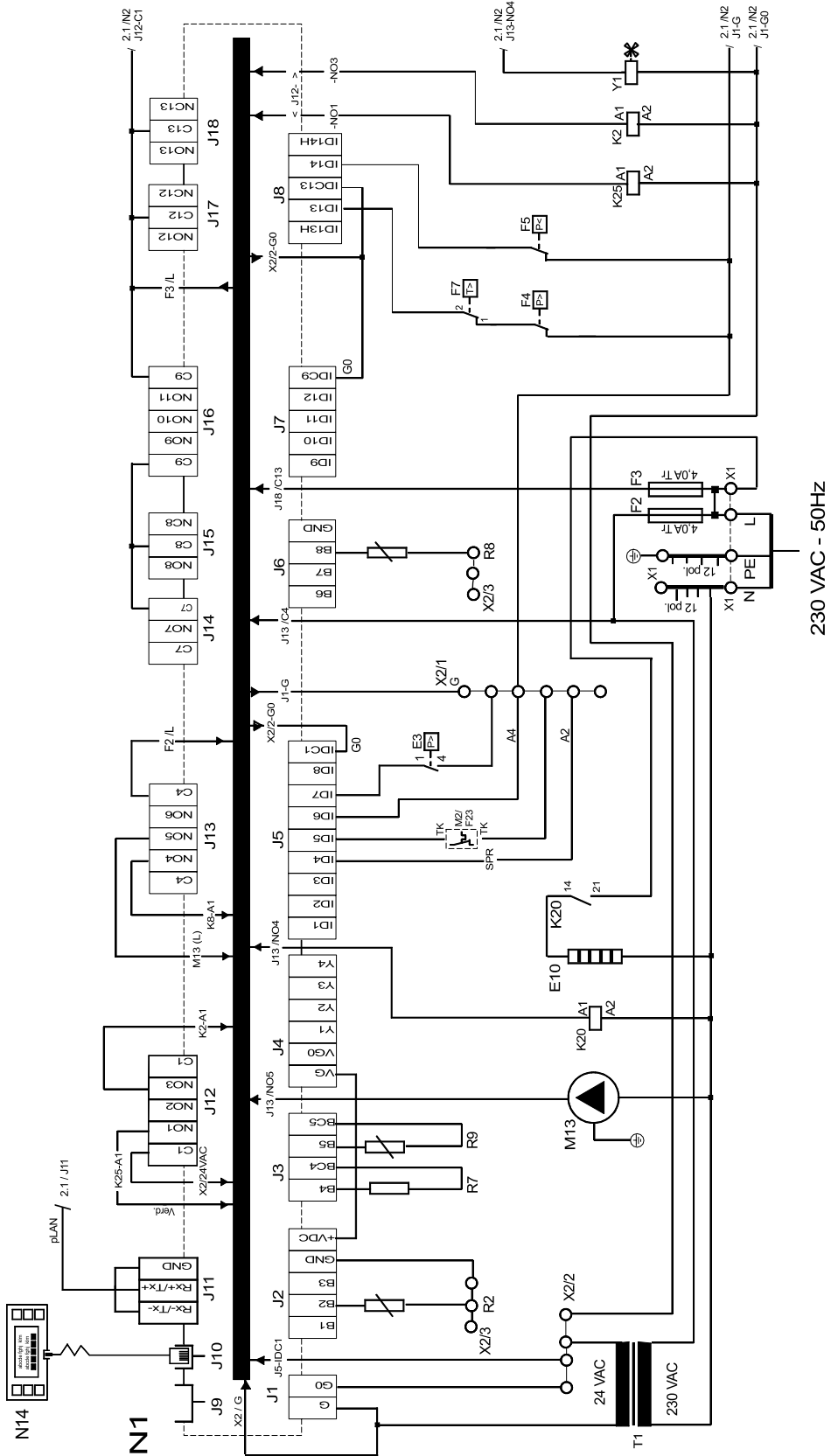

Anhang · Appendix · Annexes

### 3.2 Steuerung Kühlregler / Control of the cooling controller / Commande régulateur standard

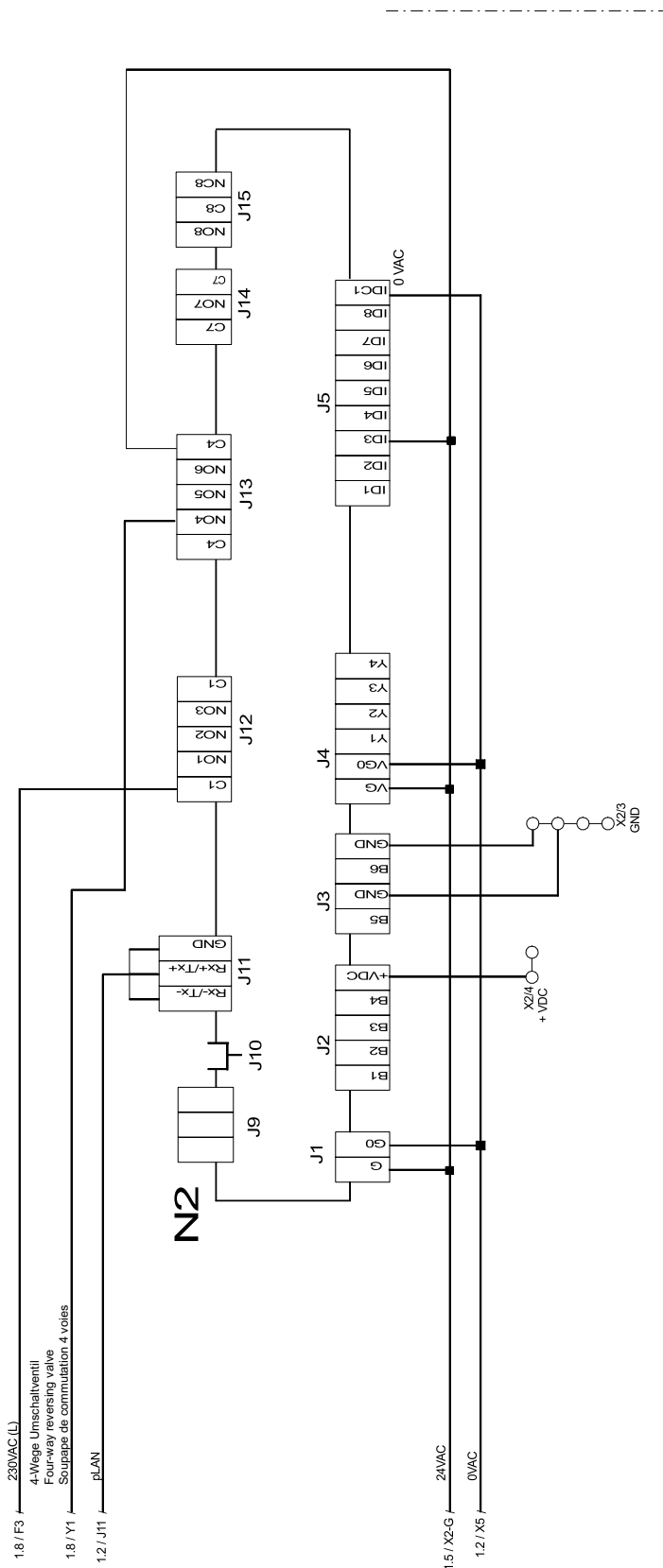

### 3.3 Last / Load / Charge

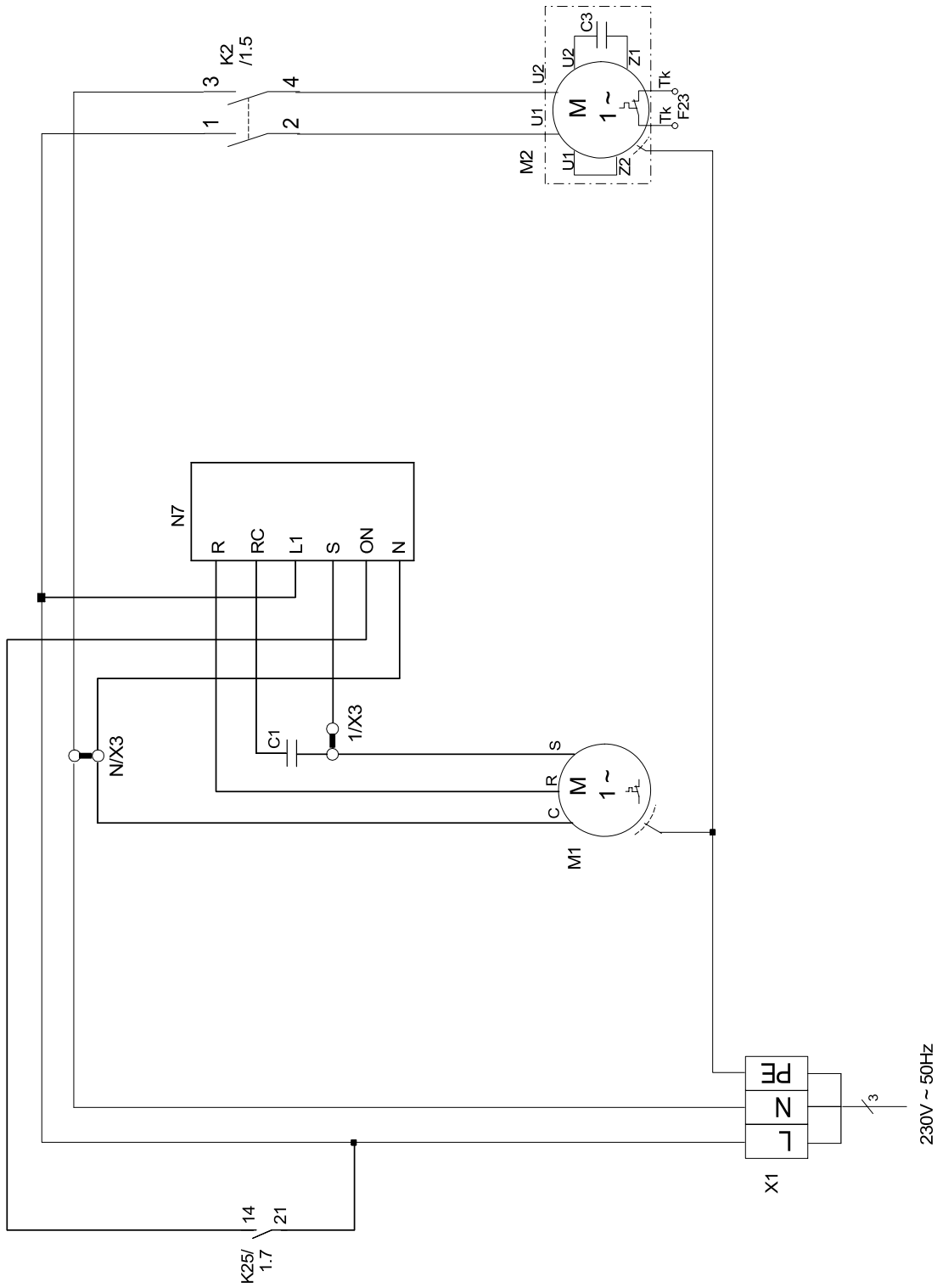

### 3.4 Anschlussplan Standardregler / Terminal diagram for the standard controller / Schéma électrique du régulateur standard

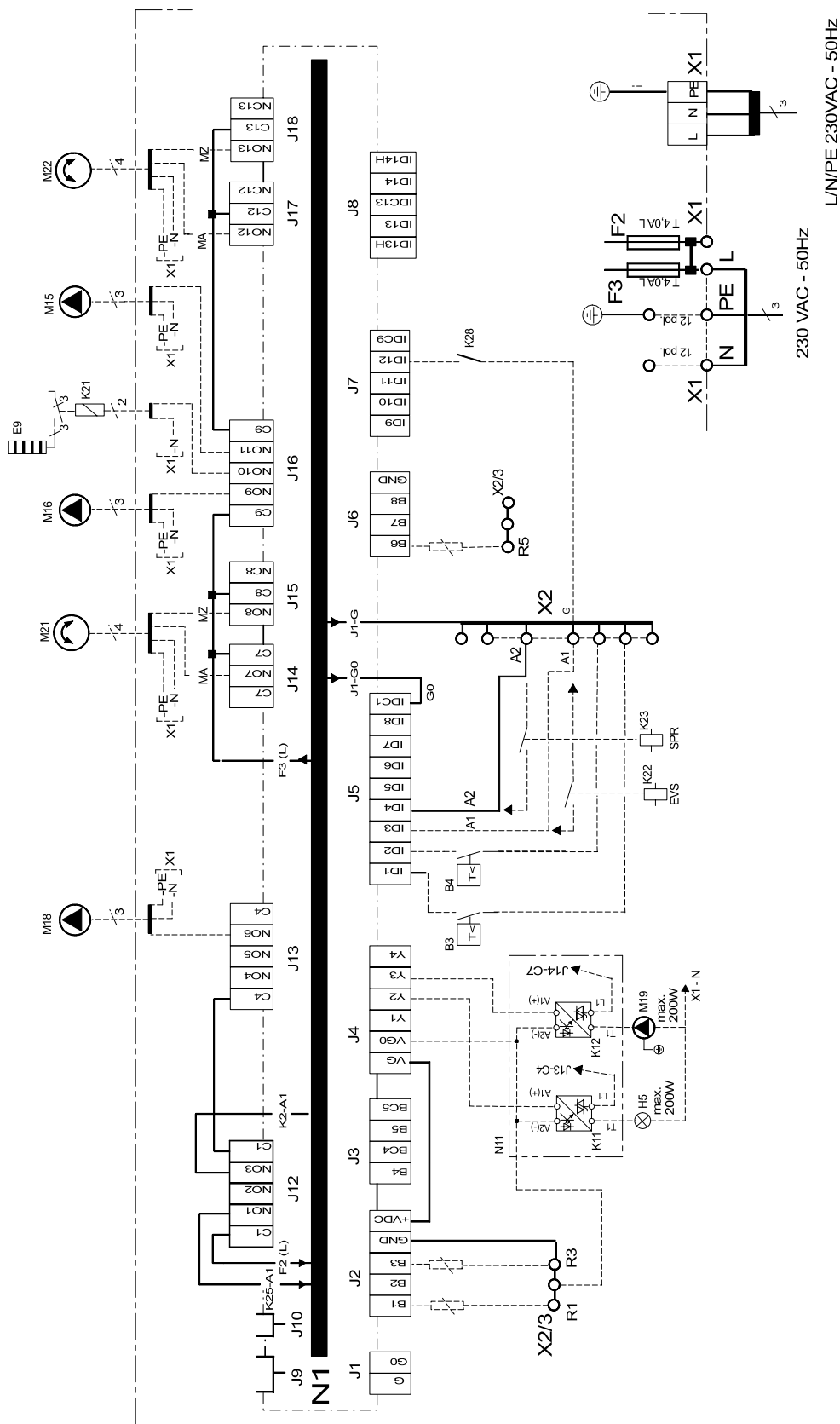

### 3.5 Anschlussplan Kühlregler / Terminal diagram for the cooling controller / Schéma électrique du régulateur refroidissement

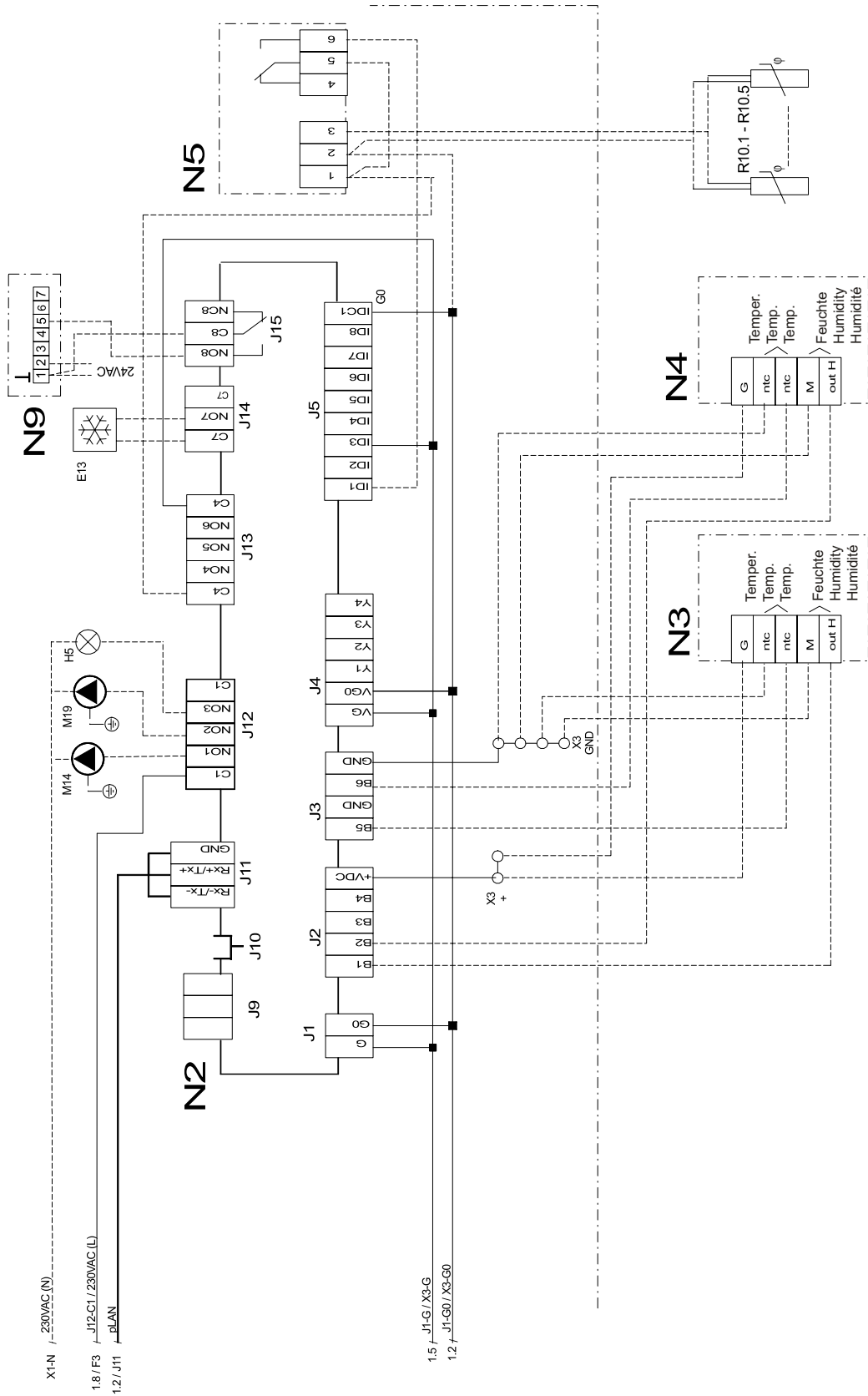

### 3.6 Legende / Legend / Légende

A1	Drahtbrücke einlegen wenn kein Sperrschütz benötigt wird (Brücke offen = EVU-Sperre = WP „aus“)	Insert wire jumper if no blocking contactor is required (bridge open = utility block = HP "off")	Cavalier à fil à insérer en absence de disjoncteur de blocage du fournisseur d'énergie (pont ouvert = blocage société électricité = PAC « arrêt »)
A2	Drahtbrücke bei Nutzung des 2ten Sperrreinganges entfernen (Brücke offen = EVU-Sperre = WP „aus“)	Remove wire jumper if disable contactor 2 is used (bridge open = utility block = HP "off")	Cavalier à fil à retirer si la 2e entrée de coupure est utilisée (pont ouvert = blocage société électricité = PAC « arrêt »)
A4	Drahtbrücke (immer eingelegt; Eingang wird bei Luft-Wasser-Wärmepumpen nicht genutzt)	Wire jumper (always inserted; input is not used for air-to-water heat pumps)	Cavalier à fil (toujours inséré ; l'entrée n'est pas utilisée pour des pompes à chaleur air/eau)
B3*	Thermostat Warmwasser	Hot water thermostat	Thermostat eau chaude
B4*	Thermostat Schwimmbadwasser	Swimming pool water thermostat	Thermostat eau de piscine
C1	Betriebskondensator Verdichter	Running capacitor, compressor	Condensateur de service - compresseur
C3	Betriebskondensator Ventilator	Running capacitor, fan	Condensateur de service - ventilateur
E3	Pressostat Abtauende	Defrost end controller	Pressostat fin de dégivrage
E9	Elekt. Tauchheizkörper Warmwasser	Electric immersion heater, hot water	Thermoplongeur élect. eau chaude
E10	2. Wärmeerzeuger Elektroheizung (Funktion ist über Regler wählbar)	2nd heat generator, electric heating (function selectable via controller)	2e générateur de chaleur chauffage électrique (fonction réglable par le régulateur)
E13*	2. Kälteerzeuger	Chiller 2	2. générateur de froid
F2	Sicherung für N1-Relaisausgänge an J12 und J13 4,0 ATr	Fuse for N1 relay outputs at J12 and J13 4.0 slow-acting	Fusible pour sorties de relais N1 en J12 et J13 4,0 ATr
F3	Sicherung für N1-Relaisausgänge an J15 bis J18 4,0 ATr	Fuse for N1 relay outputs at J15 to J18 4.0 slow-acting	Fusible pour sorties de relais N1 en J15 jusqu'à J18 4,0 ATr
F4	Pressostat Hochdruck	High-pressure switch	Pressostat haute pression
F5	Pressostat Niederdruck	Low-pressure switch	Pressostat basse pression
F7	Heißgasthermostat	Hot gas thermostat	Thermostat gaz de chauffage
F23	Wicklungsschutz Ventilator	Winding protection, ventilator	Blindage de l'enroulement ventilateur
H5*	Leuchte Störferrnanzeige	Remote fault indicator lamp	Témoin de télédétection de pannes
<b>N1:</b>			
J1	Stromversorgung-N1 (24VAC)	Power supply N1 (24 V AC)	Alimentation en courant N1 (24 V AC)
J2...J3	Sensoreingänge	Sensor inputs	Entrées de capteurs
J4	Analogausgänge, werden nicht genutzt	Analogue outputs are not used	Sorties analogiques libres
J7...J8	Digitaleingänge	Digital inputs	Entrées numériques
J9	Ohne Funktion	Has no function	Sans fonction
J10	Steckdose für Fernbedienung	Socket for remote control	Prise pour la télécommande
J11	pLAN-Anschluss	Connection for pLAN	Connexion pLAN
J12	Relaisausgänge für Verdichter und Ventilator	Relay outputs for compressor and ventilator	Sorties de relais pour compresseur et ventilateur
J13...J18	Relaisausgänge zur Ansteuerung der Systemkomponenten (230 VAC)	Relay outputs for controlling system components (230 V AC)	Sorties de relais pour la commande des composants du système (230 V AC)
<b>N2:</b>			
J1	Stromversorgung-N2 (24VAC)	Power supply N2 (24 V AC)	Alimentation en courant N2 (24 V AC)
J2...J3	Sensoreingänge	Sensor inputs	Entrées de capteurs
J4	Analogausgänge, werden nicht genutzt	Analogue outputs are not used	Sorties analogiques libres
J5	Digitaleingänge	Digital inputs	Entrées numériques
J9	Ohne Funktion	Has no function	Sans fonction
J10	Steckdose für Fernbedienung	Socket for remote control	Prise pour la télécommande
J11	pLAN-Anschluss	Connection for pLAN	Connexion pLAN
J12	Relaisausgänge für M14, M19 und H5 (230 VAC)	Relay outputs for M14, M19 and H5 (230 V AC)	Sorties de relais pour M14, M19 et H5 (230 V AC)
J13...J18	Relaisausgänge zur Ansteuerung der Systemkomponenten (230 VAC)	Relay outputs for controlling system components (230 V AC)	Sorties de relais pour la commande des composants du système (230 V AC)
K2	Schütz Ventilator	Contacteur for ventilator	Contacteur ventilateur
K11*	Elektron. Relais f. Störferrnanzeige (Relaisbaugruppe)	Electron. remote fault indicator relay (relay module)	Relais pour télédétection de pannes (sur module de relais)
K12*	Elektron. Relais f. Schwimmbadwasserumwälzpumpe (Relaisbaugruppe)	Electron. relay for swimming pool water circulating pump (relay module)	Relais pour circulateur d'eau de piscine (sur module de relais)
K20	Relais 2. Wärmeerzeuger	Relay, back-up heater	Relais chauffage complémentaire
K21*	Schütz Elekt. Tauchheizkörper Warmwasser	Contacteur electric immersion heater, hot water	Contacteur, thermoplongeur élect. eau chaude
K22*	EVU-Sperrschütz	Utility blocking contactor	Contacteur de coupure du fournisseur d'énergie
K23*	SPR-Hilfsrelais	SPR auxiliary relay	Relais auxiliaire « SPR »
K25	Startrelais für N7	Starting relay for N7	Relais de démarrage pour N7
K28*	Anforderung Kühlbetrieb	Cooling operation request	Demande mode rafraîchissement
M1	Verdichter	Compressor	Compresseur
M2	Ventilator	Ventilator	Ventilateur
M13*	Heizungsumwälzpumpe	Heat circulating pump	Circulateur de chauffage
M14*	Heizungsumwälzpumpe 1. Heizkreis	Heat circulating pump of heating circuit 1	Circulateur de chauffage 1er circuit de chauffage
M15*	Heizungsumwälzpumpe 2. Heizkreis	Heat circulating pump for heating circuit 2	Circulateur de chauffage 2e circuit de chauffage
M16*	Zusatzumwälzpumpe	Auxiliary circulating pump	Circulateur supplémentaire
M18*	Warmwasserumwälzpumpe	Hot water circulating pump	Circulateur d'eau chaude
M19*	Schwimmbadwasserumwälzpumpe	Swimming pool water circulating pump	Circulateur d'eau de piscine
M21*	Mischer Hauptkreis	Mixer for main circuit	Mélangeur circuit principal
M22*	Mischer 2. Heizkreis	Mixer for heating circuit 2	Mélangeur 2e circuit de chauffage
N1	Wärmepumpenregler	Heat pump controller	Régulateur de pompe à chaleur
N2	Kühlregler	Cooling controller	Régulateur refroidissement
N3/N4*	Raumstationen	Room stations	Stations de pièce
N5*	Taupunktschalter	Dew point switch	Interrupteur du point de condensation
N7	Sanftanlaufsteuerung	Soft start control	Commande de démarrage progressif
N9*	Raumtemperaturregler	Room temperature controller	Régulateur de température ambiante
N11*	Relaisbaugruppe	Relay module	Module de relais
N14	Bedienteil	Operating element	Commande







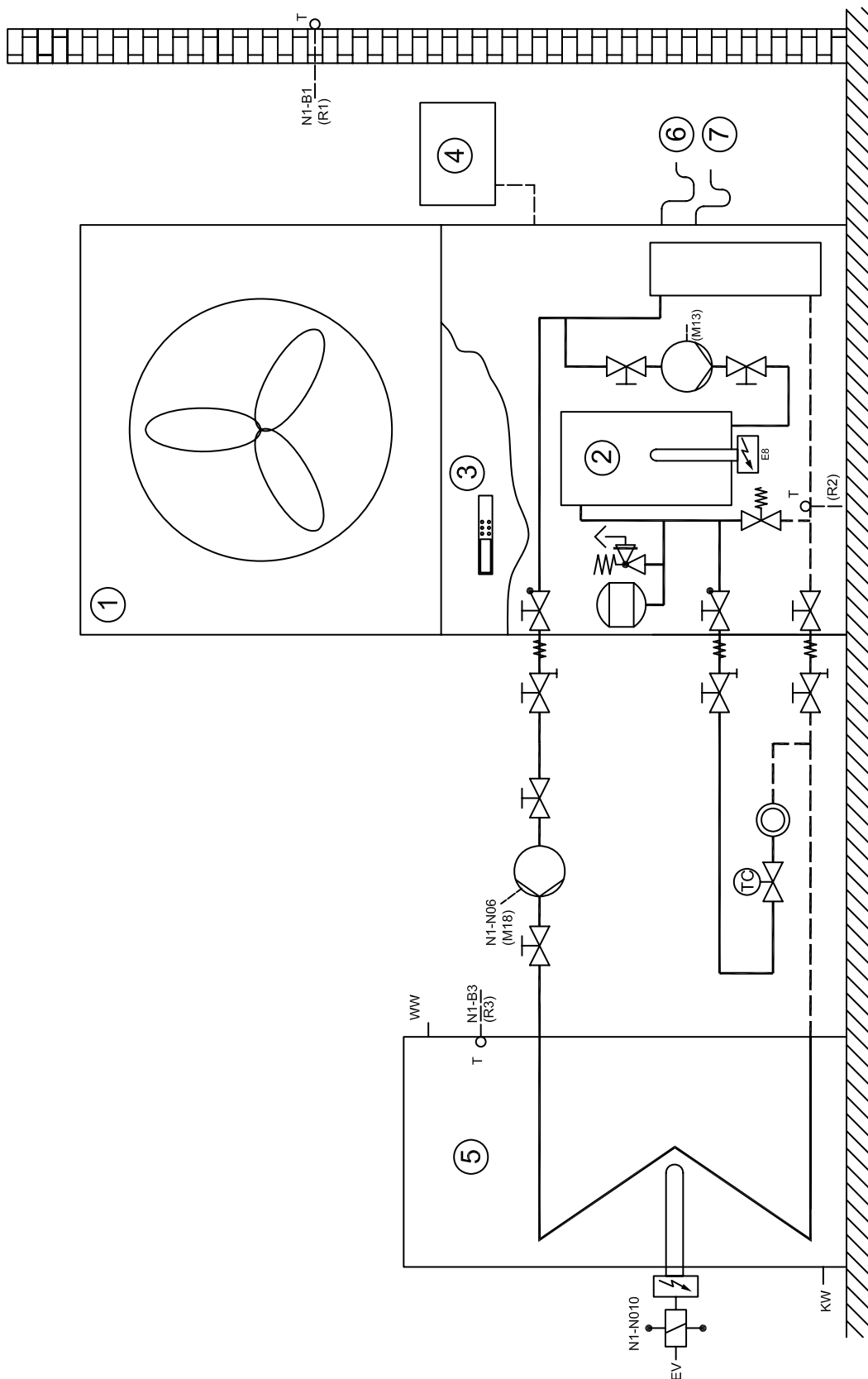



R1	Außentemperaturfühler	External temperature sensor	Sonde de température extérieure
R2	Rücklauffühler-Heizung	Return flow sensor for heating system	Sonde retour chauffage
R3	Warmwasserfühler (alternativ zum Warmwasserthermostat)	Hot water sensor (as an alternative to the hot water thermostat)	Sonde d'eau chaude (alternative au thermostat eau chaude)
R5	Fühler für den 2ten Heizkreislauf	Sensor for heating circuit 2	Sonde pour le 2e circuit de chauffage
R7	Codierwiderstand 28k7	Coding resistor 28,7 kOhm	Résistance de codage 28k7
R8	Frostschutzhühler Kälte	Flow sensor, cold	Sonde antigel froid
R9	Frostschutzhühler Heizwasser	Flow sensor, heating water	Sonde antigel eau de chauffage
R10.1-5	Feuchtesensor für N5 (maximal 5 Sensoren)	Humidity sensor for N5 (max. of 5 sensors)	Capteur d'humidité pour N5 (5 capteurs au maximum)
T1	Sicherheitstrenntransformator 230/24 VAC-50Hz/50VA	Safety isolating transformer 230/24 V AC-50 Hz/50 VA	Transformateur sectionneur de sécurité 230/24 VAC-50Hz/50VA
X1	Klemmenleiste: Netz-Last L/N/PE 230VAC-50Hz / -Steuerung L/N/PE-230VAC-50Hz; N- und PE-Verteiler	Terminal strip: mains load L/N/PE-230 V AC - 50 Hz / - control L/N/PE-230 V AC-50 Hz; N and PE terminal block	Bornier distributeur : charge réseau L/N/PE-230 V AC-50 Hz / -commande L/N/PE-230 V AC-50 Hz ; distributeur N et PE
X2/1	Klemmenleiste: Verteiler für 24VAC	Terminal strip: terminal block for 24 V AC	Bornier distributeur : distributeur pour 24 V AC
X2/2	Klemmenleiste: Verteiler für 0VAC	Terminal strip: terminal block for 0 V AC	Bornier distributeur : distributeur pour 0 V AC
X2/3	Klemmenleiste: Verteiler für DC / Ground (-)	Terminal strip: terminal block for DC / ground (-)	Bornier distributeur : distributeur pour DC / Ground (-)
X2/4	Klemmenleiste: Verteiler für DC / Plus (+)	Terminal strip: terminal block for DC / plus (+)	Bornier distributeur : distributeur pour DC / Plus (+)
X3	Klemmenleiste: Verdichter	Terminal strip: Compressor	Bornier distributeur : Compresseur
Y1	Vier-Wege-Umschaltventil	Four-way valve	Vanne d'inversion 4 voies
	<b>Abkürzungen:</b>	<b>Abbreviations:</b>	<b>Abbréviations :</b>
EVS	EVU-Sperreingang	Utility disable contactor	Entrée de coupure fournisseur d'énergie
SPR	Zusätzlicher Sperreingang	Supplementary disable contactor	Entrée de « coupure courant » complémentaire
MA*	Mischer AUF	Mixer OPEN	Mélangeur OUVERT
MZ	Mischer ZU	Mixer CLOSED	Mélangeur FERME
*	Bauteile sind extern beizustellen	Components to be supplied from external sources	Pièces à fournir par le client
-----	bauseits bei Bedarf anzuschließen	To be connected by the customer as required	à raccorder par le client au besoin
—	werkseitig verdrahtet	Wired ready for use	câblé départ usine

# 4 Hydraulisches Prinzipschema / Hydraulic Plumbing Diagram / Schéma hydraulique

## 4.1 Darstellung / Schematic view / Représentation



## 4.2 Legende / Legend / Légende

	Absperrventil	Shutoff valve	Robinet d'arrêt
	Überstromventil	Overflow valve	Vanne de trop-plein
	Sicherheitsventilkombination	Safety valve combination	Groupe de valves de sécurité
	Umwälzpumpe	Circulating pump	Circulateur
	Ausdehnungsgefäß	Expansion vessel	Vase d'expansion
	Raumtemperaturgesteuertes Ventil	Room temperature-controlled valve	Valve commandée par température
	Absperrventil mit Rückschlagventil	Shutoff valve with check valve	Robinet d'arrêt avec clapet anti-retour
	Absperrventil mit Entwässerung	Shutoff valve with drainage	Robinet d'arrêt avec écoulement
	Wärmeverbraucher	Heat consumer	Consommateur de chaleur
	Temperaturfühler	Temperature sensor	Sonde de température
	Flexibler Anschlusschlauch	Flexible connection hose	Tuyau de raccord flexible
①	Wärmepumpe	Heat pump	Pompe à chaleur
②	Pufferspeicher	Buffer tank	Réservoir tampon
③	Wärmepumpenregler	Heat pump controller	Régulateur de pompe à chaleur
④	Elektroverteilung	Electrical distribution system	Distributeur courant électrique
⑤	Warmwasserspeicher	Hot water cylinder	Ballon d'eau chaude
⑥	Kondensatablauf	Condensate outflow	Ecoulement des condensats
⑦	Überdruck Heizwasser	Overpressure of the heating water	Surpression eau de chauffage
E8	Zusatzheizung	Supplementary heating	Chauffage d'appoint
M13	Heizungsumwälzpumpe	Heat circulating pump	Circulateur de chauffage
M18	Warmwassersumwälzpumpe	Hot water circulating pump	Circulateur d'eau chaude
N1	Wärmepumpenregler	Heat pump controller	Régulateur de pompe à chaleur
R1	Außentemperaturfühler	External temperature sensor	Sonde de température extérieure
R2	Rücklauffühler	Return flow sensor	Sonde de retour
R3	Warmwasserfühler	Hot water sensor	Sonde d'eau chaude
EV	Elektroverteilung	Electrical distribution system	Distributeur courant électrique
KW	Kaltwasser	Cold water	Eau froide
MA	Mischer AUF	Mixer OPEN	Mélangeur OUVERT
WW	Warmwasser	Domestic hot water	Eau chaude

# 5 Konformitätserklärung / Declaration of Conformity / Déclaration de conformité

## EG - Konformitätserklärung EC Declaration of Conformity Déclaration de conformité CE

Der Unterzeichnete  
The undersigned  
La société soussignée,

**Glen Dimplex Deutschland GmbH**  
**Geschäftsbereich Dimplex**  
**Am Goldenen Feld 18**  
**D - 95326 Kulmbach**

bestätigt, dass das (die) nachfolgend be-  
zeichnete(n) Gerät(e) aufgrund seiner (ihrer)  
Konzipierung und Bauart sowie in der von  
uns in Verkehr gebrachten Ausführung den  
entschlagigen grundlegenden Anforderungen  
der EG-Richtlinien entspricht (entsprechen).

Bei einer nicht mit uns abgestimmten  
Änderung des (der) Gerät(e)s verliert  
diese Erklärung ihre Gültigkeit.

hereby confirm that the design and con-  
struction of the product(s) listed below,  
in the version(s) placed on the market by  
us, conform to the relevant requirements  
of the applicable EC directives.

This declaration becomes invalidated  
if any modifications are made to  
the product(s) without our prior  
authorisation.

certifie que l'appareil / les appareils ci-  
après, par leur conception et leur mode de  
construction ainsi que par la définition  
technique avec laquelle il(s) sont mis en  
circulation par notre société, est / sont  
conforme(s) aux directives fondamentales  
CEE afférentes.

Ce certificat perd sa validité pour tout  
appareil modifié sans notre consentement.

### Bezeichnung / Designation / Désignation

**Luft/Wasser-Wärmepumpen**  
für Innenaufstellung mit R404A

**Air-to-water heat pumps**  
for indoor installation, containing R404A

**Pompes à chaleur air/eau**  
pour installation intérieure avec R404A

### EG - Richtlinien / EC Directives / Directives CEE

EG- Niederspannungsrichtlinie / EC Low Voltage Directive /  
Directive CEE relative à la basse tension (2006/95/EG)

EG-EMV-Richtlinie / EC EMC Directive / Directive CEE  
relative à la compatibilité électromagnétique (89/336/EWG)

Druckgeräterichtlinie / Pressure Equipment Directive /  
Directive CEE relative aux appareils sous pression (97/23/EG)

### Typ(e):

### Harmonisierte EN / Harmonized EB Standards / Normes EN harmonisées:

#### **LIK 8MER**

EN 255:1997  
EN 378:2000  
DIN 8901

DIN EN 60335-1 (VDE 0700 T1):2006

DIN EN 60335-2-40 (VDE 0700 T40):2006-11

DIN EN 55014-1 (VDE 0875 T14-1):2003-09

DIN EN 55014-2 (VDE 0875 T14-2):2002-08

DIN EN 61000-3-2 (VDE 0838 T2):2005-09

DIN EN 61000-3-3 (VDE 0838 T3):2002-05

EN 60335-1:2002+A11+A1+A12+  
Corr.+A2:2006

EN 60335-2-40:2003+A11+A12+A1+Corr.:2006

EN 55014-1:2000+A1:2001+A2:2002

EN 55014-2:1997+A1:2001

EN 61000-3-2:2000+A2:2005

EN 61000-3-3:1995+Corr.:1997+A1:2001

### Nationale Richtlinien / National Directives / Directives nationales

D  
BGR 500

A

CH  
SVTI

Kulmbach, 09.02.2007

CE02W011.doc

  
Wolfgang Weinhold

Geschäftsführer / Managing Director

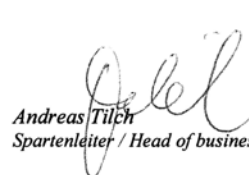
  
Andreas Tilch

Spartenleiter / Head of business unit

