

SI 24TE
SI 37TE

Dimplex

**Montage- und
Gebrauchsanweisung**

Deutsch

**Installation and
Operating Instructions**

English

**Instructions d'installation
et d'utilisation**

Français

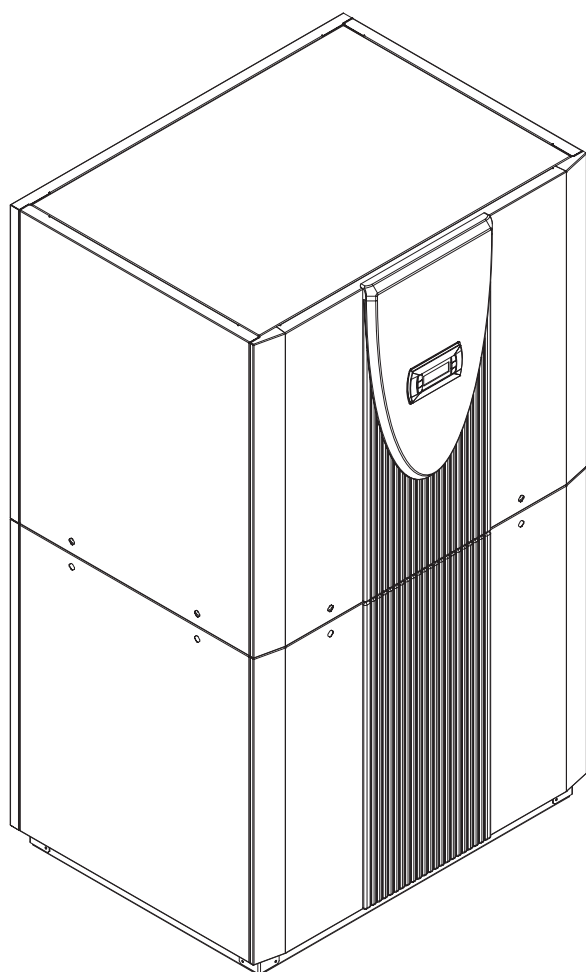

**Sole/Wasser-
Wärmepumpe für
Innenaufstellung**

**Brine-to-Water
Heat Pump for
Indoor Installation**

**Pompe à chaleur
eau glycolée-eau
pour installation
intérieure**

Table of contents

1	Read immediately	E-2
1.1	Important Information	E-2
1.2	Legal Provisions and Guidelines	E-2
1.3	Energy-Efficient Use of the Heat Pump	E-2
2	Purpose of the heat pump	E-2
2.1	Application	E-2
2.2	Principle of Operation	E-2
3	Baseline Unit	E-3
4	Accessories	E-3
4.1	Connecting Flanges.....	E-3
5	Transport	E-3
6	Installation	E-4
6.1	General Information	E-4
6.2	Sound Emissions	E-4
7	Mounting	E-4
7.1	General Information	E-4
7.2	Connection on Heating Side	E-4
7.3	Connection on Heat Source Side	E-4
7.4	Electrical Connection	E-4
8	Commissioning	E-5
8.1	General Information	E-5
8.2	Preparatory Steps.....	E-5
8.3	Commissioning Procedure.....	E-5
9	Care/Cleaning	E-6
9.1	Care	E-6
9.2	Cleaning og Heating Side	E-6
9.3	Cleaning of Heat Source Side	E-6
10	Malfunctions / Troubleshooting	E-6
11	Decommissioning / Disposal	E-6
12	Equipment Data	E-7
	Anhang / Appendix / Annexes	A-I

1 Read immediately

1.1 Important Information

⚠ ATTENTION!

Any work on the heat pump may only be performed by an authorised and qualified customer service.

⚠ ATTENTION!

The heat pump must not be tilted more than max. 45° (in either direction).

⚠ ATTENTION!

The transport securing devices must be removed prior to commissioning.

⚠ ATTENTION!

The heating system must be flushed prior to connecting the heat pump.

⚠ ATTENTION!

The supplied strainer must be fitted in the heat source inlet of the heat pump in order to protect the evaporator against the ingress of impurities.

⚠ ATTENTION!

The brine solution must contain at least 25 % of an antifreeze agent on a mono-ethylene glycol or propylene glycol basis and must be mixed prior to filling.

⚠ ATTENTION!

The clockwise phase sequence must be observed when connecting the load lines (the heat pump will deliver no output and will be very noisy when the phase sequence is incorrect).

⚠ ATTENTION!

Commissioning is to be effected in accordance with the installation and operating manual of the heat pump controller.

⚠ ATTENTION!

To prevent the accumulation of deposits (e.g. rust) we recommend using a suitable corrosion protection system.

⚠ ATTENTION!

Disconnect all electrical circuits from the power supply before opening the enclosure.

1.2 Legal Provisions and Guidelines

This heat pump conforms to all relevant DIN/VDE regulations and EU directives. For details refer to the EC Declaration of Conformity in the appendix.

The electrical connection of the heat pump must be performed according to and conforming with all relevant VDE, EN and IEC standards. Beyond that, the connection requirements of the local utility companies have to be observed.

The heat pump is to be connected to the heat source and heat distribution systems in accordance with all applicable provisions.

⚠ ATTENTION!

Any work on the heat pump may only be performed by an authorised and qualified customer service.

1.3 Energy-Efficient Use of the Heat Pump

By operating this heat pump you contribute to the protection of our environment. A prerequisite for an efficient operation is the proper design and sizing of the heating system and the heat source system. In particular, it is important to keep water flow temperatures as low as possible. All energy consumers connected should therefore be suitable for low flow temperatures. A 1 K higher heating water temperature corresponds to an increase in power consumption of approx. 2.5 %. Low-temperature heating systems with flow temperatures between 30 °C and 50 °C are optimally suited for energy-efficient operation.

2 Purpose of the heat pump

2.1 Application

The brine-to-water heat pump is designed for use in existing or newly built heating systems. Brine is used as the heat carrier in the heat source system. Ground coils, ground collectors or similar systems can be used as the heat source.

2.2 Principle of Operation

The heat generated by the sun, wind and rain is stored in the ground. This heat stored in the ground is collected at low temperature by the brine circulating in the ground collector, ground coil or similar device.

A circulating pump then conveys the warmed brine to the evaporator of the heat pump. There, the heat is given off to the refrigerant in the refrigeration cycle. When so doing, the brine cools so that it can again take up heat energy in the brine circuit.

The refrigerant is drawn in by the electrically driven compressor, is compressed and "pumped" to a higher temperature level. The electrical power needed to run the compressor is not lost in this process, but most of the generated heat is transferred to the refrigerant.

Subsequently, the refrigerant is passed through the condenser where it transfers its heat energy to the heating water. Based on the thermostat setting, the heating water is thus heated to up to 60 °C.

3 Baseline Unit

The baseline unit consists of a heat pump, ready for connection, for indoor installation, complete with sheet metal cabinet, control box and integrated controller. The refrigeration cycle contains the refrigerant R404A. Refrigerant R404A is CFC-free, non-ozone depleting and non-combustible.

All components required for the operation of the heat pump are located in the control box. A sensor for the external wall temperature including mounting hardware as well as a strainer are supplied with the heat pump. The voltage supply for the load and control current must be provided by the customer.

The control wire of the brine pump (to be provided by the customer) is to be connected to the control box. When so doing, a motor protecting device is to be installed, if required.

The collector including the brine manifold must be provided by the customer.

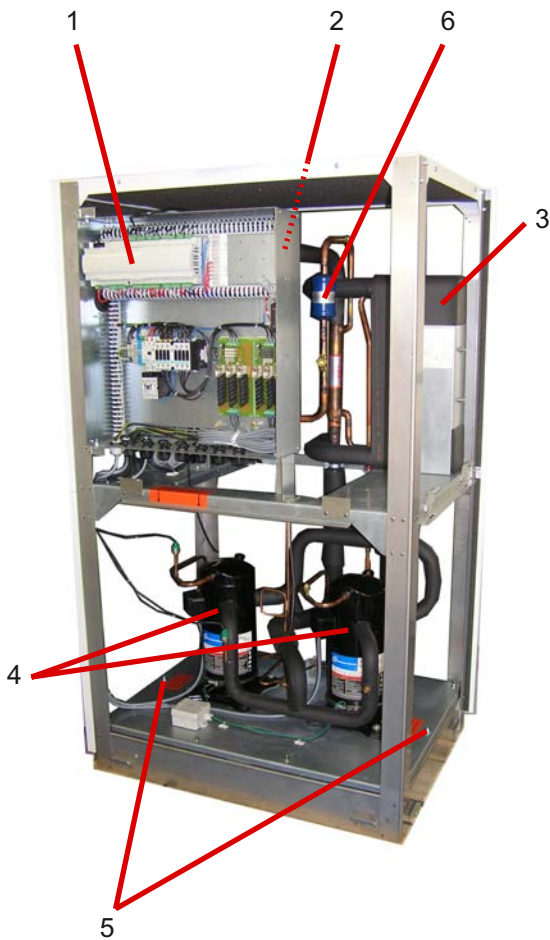

- 1) Control
- 2) Evaporator
- 3) Condenser
- 4) Compressor
- 5) Transport securing devices
- 6) Filter drier

4 Accessories

4.1 Connecting Flanges

The use of flat-sealing connecting flanges allows the unit, as an option, to be connected by means of flanges.

5 Transport

For the transport by means of a hand truck or boiler trolley, position the latter under the front end of the unit below the transport security device.

For transport on a level surface, the unit can be lifted from the rear or from the front by means of a lift truck or forklift. In this case, the transport securing device is not imperative.

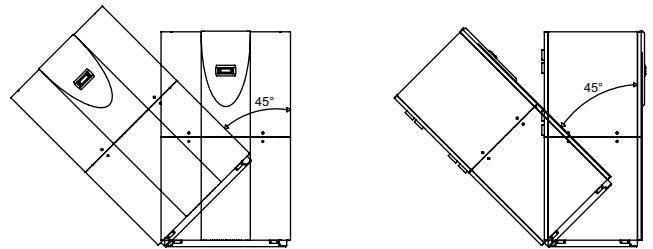

⚠ ATTENTION!

The heat pump must not be tilted more than max. 45° (in either direction).

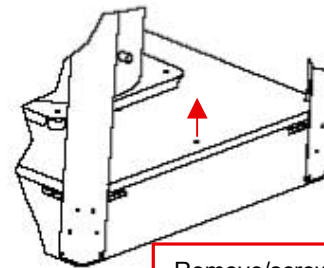

Remove/screw in
transport lock

After the transport, the transport securing device is to be removed on either side at the bottom of the unit.

⚠ ATTENTION!

The transport securing device is to be removed prior to commissioning.

To remove the panelling, open the individual covers by unscrewing the respective turn-lock fasteners and then gently tilting the covers away from the device. Then lift them up out of the mountings.

6 Installation

6.1 General Information

As a rule, the unit must be installed indoors on a level, smooth and horizontal surface. The entire base frame should make full contact with the surface in order to ensure adequate sound insulation. Failing this, additional sound insulation measures may become necessary.

The heat pump should be installed to allow easy maintenance/service access. This is ensured if a clearance of approx. 1 m in front of the heat pump is maintained.

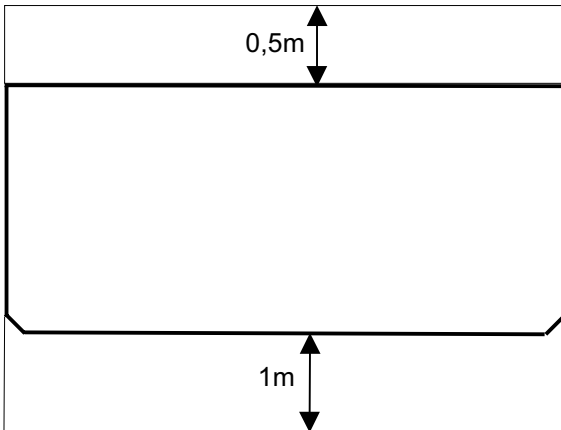

6.2 Sound Emissions

The heat pump offers silent operation due to efficient sound insulation. Any vibration transmission to the foundation or the heating system can be largely prevented by internal sound decoupling measures.

7 Mounting

7.1 General Information

The following connections need to be established on the heat pump:

- supply/return flow of the brine system
- supply/return flow of the heating system
- power supply

7.2 Connection on Heating Side

⚠ ATTENTION!

The heating system must be flushed prior to connecting the heat pump.

Before completing the heat pump connections on the heating water side, the heating installation must be flushed in order to remove any impurities that may be present, as well as residues of sealing material, and the like. Any accumulation of deposits in the condenser may result in a total failure of the heat pump.

Once the installation on the heating side has been completed, the heating system must be filled, de-aerated and pressure-tested.

Heating water minimum flow rate

The heating water minimum flow rate through the heat pump must be assured in all operating states of the heating system. This can be accomplished, for example, by installing a differential pressure-free manifold or an overflow valve. The procedure for setting an overflow valve is described in the Chapter Commissioning.

Frost protection for installations prone to frost

Provided the controller and heating circulating pumps are ready for operation, the frost protection feature of the controller is active. If the heat pump is taken out of service or in the event of a power failure, the system has to be drained. In heat pump installations where a power failure cannot be readily detected (holiday house), the heating circuit must contain a suitable antifreeze product.

7.3 Connection on Heat Source Side

The following procedure must be observed when making the connection:

Connect the brine line to the flow and return pipe of the heat pump.

The hydraulic plumbing diagram must be observed here.

⚠ ATTENTION!

The supplied strainer must be fitted in the heat source inlet of the heat pump in order to protect the evaporator against the ingress of impurities.

In addition, a microbubble deaerator must be installed in the heat source system.

The brine liquid must be produced prior to charging the system. The brine concentration must be at least 25 %. Freeze protection down to -14°C can thus be ensured.

Only antifreeze products on the basis of mono-ethylene glycol or propylene glycol may be used.

The heat source system must be vented (de-aerated) and checked for leaks.

⚠ ATTENTION!

The brine solution must contain at least 25 % of an antifreeze agent on a mono-ethylene glycol or propylene glycol basis and must be mixed prior to filling.

7.4 Electrical Connection

The following electrical connections must be established on the heat pump:

- Connection of the control wire to terminals X1: L/N/PE in the control box of the heat pump.
- Connection of the load wire to terminals X5: L1/L2/L3/PE in the control box of the heat pump.
- Connection of the brine pump (to be supplied by the customer) to terminal PE and pump contactor K5: 2/4/6 on the control panel of the HP.

All electrical components required for the operation of the heat pump are located in the control box.

For more detailed instructions concerning the connection and functioning of the heat pump controller (e.g. the supplied external wall sensor) please refer to the enclosed operating manual of the controller.

An automatic circuit-breaker with simultaneous tripping of all external conductors is to be provided in the load power supply. The circuit-breaker must be an all-pole disconnect device with a contact gap of at least 3 mm. The same applies to any additional disable contactors that may be required, e.g. during shut-off periods imposed by the utility company. The required cross-sectional area of the conductors is to be selected according to the power consumption of the heat pump, the technical connection requirements of the relevant utility company and all applicable regulations. Power consumption data of the heat pump is provided in the product literature and on the nameplate. The terminals are designed for a max. conductor cross-section of 35 mm².

⚠ ATTENTION!

The clockwise phase sequence must be observed when connecting the load lines (the heat pump will deliver no output and will be very noisy when the phase sequence is incorrect).

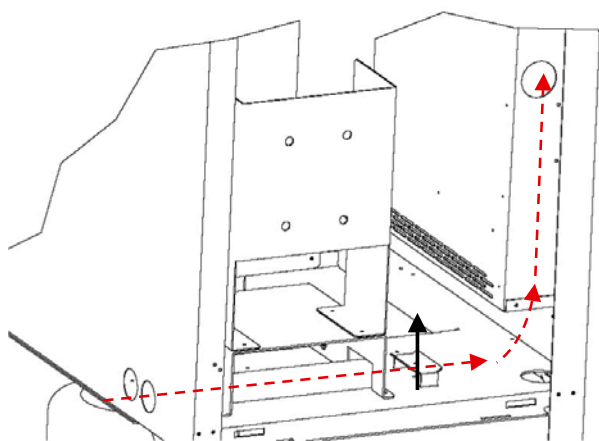

The power cable must be run through the guide tubes, inserted into the side of the control box and secured by means of the strain relief.

8 Commissioning

8.1 General Information

To ensure proper commissioning it should be carried out by a customer service authorised by the manufacturer. This will lead, under certain circumstances, to an extension of the warranty period (cf. Warranty).

8.2 Preparatory Steps

Prior to commissioning, the following items need to be checked:

- All connections of the heat pump must have been made as described in Chapter 7.
- The heat source system and the heating circuit must have been filled and checked.
- The strainer must have been fitted in the sole inlet of the heat pump.
- In the brine and heating circuits all valves that might impair the proper flow must be open.
- The settings of the heat pump controller must be adapted to the heating installation in accordance with the instructions contained in the controller's operating manual.

8.3 Commissioning Procedure

The start-up of the heat pump is effected via the heat pump controller.

⚠ ATTENTION!

Commissioning is to be effected in accordance with the installation and operating manual of the heat pump controller.

Where an overflow valve is fitted to assure the minimum heating water flow rate, the valve must be set in accordance with the requirements of the heating installation. An incorrect setting may result in various error symptoms and an increased electric power consumption. To correctly set the overflow valve, the following procedure is recommended:

Close all of the heating circuits which may also be closed during operation (depending on the type of heat pump usage) so that the least favourable operating state - with respect to the water flow rate - is achieved. Normally, these heating circuits are those of the rooms located on the south and west sides of buildings. At least one heating circuit must remain open (e.g. bathroom).

The overflow valve is to be opened to such an extent that based on the current heat source temperature the maximum temperature difference between heating supply and return flow temperature is obtained, as indicated in the table below. The temperature difference should be measured as closely to the heat pump as possible. In mono-energetic systems, the electric heating element is to be deactivated.

Heat source temperature		max. difference between heating supply and return temperature
from	to	
-5° C	0° C	10 K
1° C	5° C	11 K
6° C	9° C	12 K
10° C	14° C	13 K
15° C	20° C	14 K
21° C	25° C	15 K

Any malfunctions occurring during operation are displayed on the heat pump controller and can be corrected as described in the operating manual of the heat pump controller.

9 Care/Cleaning

9.1 Care

The heat pump is maintenance-free. To prevent malfunctions due to sediments in the heat exchangers, care must be taken that no impurities can enter the heat source system and the heating installation. In the event that operating malfunctions due to contamination occur nevertheless, the system should be cleaned as described below.

9.2 Cleaning og Heating Side

The ingress of oxygen into the heating water circuit, in particular if it contains steel components, may result in the formation of oxidation products (rust). These can enter the heating system via valves, circulating pumps or plastic tubing. It is therefore important - in particular with respect to the piping of underfloor heating systems - that the installation be executed in a diffusion-proof manner.

⚠ ATTENTION!

To prevent the accumulation of deposits (e.g. rust) we recommend using a suitable corrosion protection system.

In the case of severe contamination leading to a reduction in the performance of the condenser in the heat pump, the system must be cleaned by a heating technician.

Based on current knowledge, we recommend cleaning with a 5% phosphoric acid solution or, in the case that cleaning needs to be performed more frequently, with a 5% formic acid solution.

In either case, the cleaning fluid should be at room temperature. It is recommended that the heat exchanger be cleaned in the direction opposite to the normal flow direction.

To prevent acidic cleaning agents from entering the circuit of the heating installation we recommend that the flushing device be fitted directly to the supply and return lines of the condenser of the heat pump.

Thereafter the system must be thoroughly flushed using appropriate neutralising agents in order to prevent any damage caused by cleaning agent residues that may still be present in the system.

All acids must be used with great care, all relevant regulations of the employers' liability insurance associations must be adhered to.

If in doubt, contact the manufacturer of the chemicals!

9.3 Cleaning of Heat Source Side

⚠ ATTENTION!

The supplied strainer must be fitted in the heat source inlet of the heat pump in order to protect the evaporator against the ingress of impurities.

The filter screen of the strainer should be cleaned one day after commissioning, thereafter every week. If no more contamination can be noticed any more, the strainer filter can be removed in order to reduce pressure losses.

10 Malfunctions / Troubleshooting

This heat pump is a quality product and designed for trouble- and maintenance-free operation. In the event that a malfunction occurs nevertheless, it will be indicated on the display of the heat pump controller. Simply consult the Malfunctions and Troubleshooting table contained in the in-stallation and operating manual of the heat pump controller (manager).

If you cannot correct the malfunction yourself, please contact the after-sales service agent in charge.

⚠ ATTENTION!

All work on the heat pump may only be performed by an authorised and qualified after-sales service.

⚠ ATTENTION!

Disconnect all electrical circuits from the power supply before opening the enclosure.

11 Decommissioning / Disposal

Before removing the heat pump, disconnect the unit from the power source and close all valves.

Environment-relevant requirements regarding the recovery, recycling and disposal of service fuels and components in accordance with all relevant standards must be adhered to. Particular attention must hereby be paid to the proper disposal of refrigerants and refrigeration oils.

12 Equipment Data

1 Type and order code		SI 24TE	SI 37TE	
2 Design				
2.1	Degree of protection according to EN 60 529	IP 21	IP 21	
2.2	Installation location	Indoors	Indoors	
3 Performance data				
3.1 Operating temperature limits:				
	Heating water flow °C	up to 60	up to 60	
	Brine (heat source) °C	-5 to +25	-5 to +25	
	Antifreeze	Monoethylene glycol	Monoethylene glycol	
	Minimum brine concentration (-13 °C freezing temperature)	25%	25%	
3.2	Temperature spread of heating water (flow/return flow) at B0 / W35K	9.4 5.0	9.8 5.0	
3.3	Heat output / COP at B-5 / W55 ¹	kW / --- ²	19.7 / 2.3	28.9 / 2.4
		kW / --- ³	9.3 / 2.1	12.1 / 2.2
	at B0 / W45 ¹	kW / --- ²		33.0 / 3.3
		kW / --- ³	22.3 / 3.1	13.4 / 2.8
	at B0 / W50 ¹	kW / --- ²	11.3 / 3.1	34.3 / 3.1
		kW / --- ³	22.7 / 2.9	13.1 / 2.4
	at B0 / W35 ¹	kW / --- ²	10.8 / 2.7	37.2 / 4.6
		kW / --- ³	24.0 / 4.3	17.0 / 4.2
		12.5 / 4.4	12.7 / 4.3	18.3 / 4.5
3.4	Sound power level			
3.5	Sound pressure level at a distance of 1 m			
3.6	Heating water flow with an internal pressure differential of m ³ /h / Pa	2.2 / 3100 4.0 / 9800	3.2 / 1650 6.0 / 5100	
3.7	Brine throughput with an internal pressure differential (heat source) of m ³ /h / Pa	5.6 / 13000 5.6 / 13000	8.5 / 10000 8.5 / 10000	
3.8	Refrigerant; total filling weight	R404A / 3.7	R404A / 6.8	
4 Dimensions, connections and weight				
4.1	Device dimensions without connections ⁴	H x W x L mm	1660 x 1000 x 775	
4.2	Device connections to heating system	Inch	G 1 1/4" internal/external	
4.3	Device connections to heat source	Inch	G 1 1/2" internal/external	
4.4	Weight of the transportable unit(s) incl. packing	kg	282	
5 Electrical connection				
5.1	Nominal voltage; fuse protection	V / A	400 / 20	
5.2	Nominal power consumption ¹ B0 W35	kW	5.61 5.81	
5.3	Starting current with soft starter	A	20	
5.4	Nominal current B0 W35 / cos φ ²	A / ---	10.12 / 0.8 10.48 / 0.8	
6	Complies with the European safety regulations	5	5	
7 Additional model features				
7.1	Water in device protected against freezing ⁶	Yes	Yes	
7.2	Performance levels	2	2	
7.3	Controller internal/external	Internal	Internal	

1. This data indicates the size and capacity of the system. For an analysis of the economic and energy efficiency of the system, both the bivalence point and the regulation should also be taken into consideration. The specified values, e.g. B10 / W55, have the following meaning: Heat source temperature 10 °C and heating water flow temperature 55 °C.

2. Operation with 2 compressor

3. Operation with 1 compressors

4. Note that additional space is required for pipe connections, operation and maintenance.

5. See CE declaration of conformity

6. The heat circulating pump and the heat pump controller must always be ready for operation.

Anhang / Appendix / Annexes

1	Maßbilder / Dimensioned drawings / Schémas cotés	A-II
1.1	Maßbild / Dimensioned drawing / Schéma coté SI 24TE	A-II
1.2	Maßbild / Dimensioned drawing / Schéma coté SI 37TE	A-III
2	Diagramme / Schematics / Diagrammes	A-IV
2.1	Kennlinien / Schematics / Courbes caractéristiques SI 24TE	A-IV
2.2	Kennlinien / Schematics / Courbes caractéristiques SI 37TE	A-V
3	Stromlaufpläne / Wiring diagrams / Schémas électriques	A-VI
3.1	Steuerung / Control / Commande	A-VI
3.2	Last / Load / Charge	A-VII
3.3	Anschlussplan / Terminal diagram / Schéma de branchement	A-VIII
3.4	Legende / Legend / Légende	A-IX
4	Hydraulisches Prinzipschema / Hydraulic block diagrams / Schéma hydraulique	A-X
4.1	Darstellung / Schematic view / Représentation schématique	A-X
4.2	Legende / Legend / Légende	A-XI
5	Konformitätserklärung / Declaration of Conformity / Déclaration de conformité	A-XII

1 Maßbilder / Dimensioned drawings / Schémas cotés

1.1 Maßbild / Dimensioned drawing / Schéma coté SI 24TE

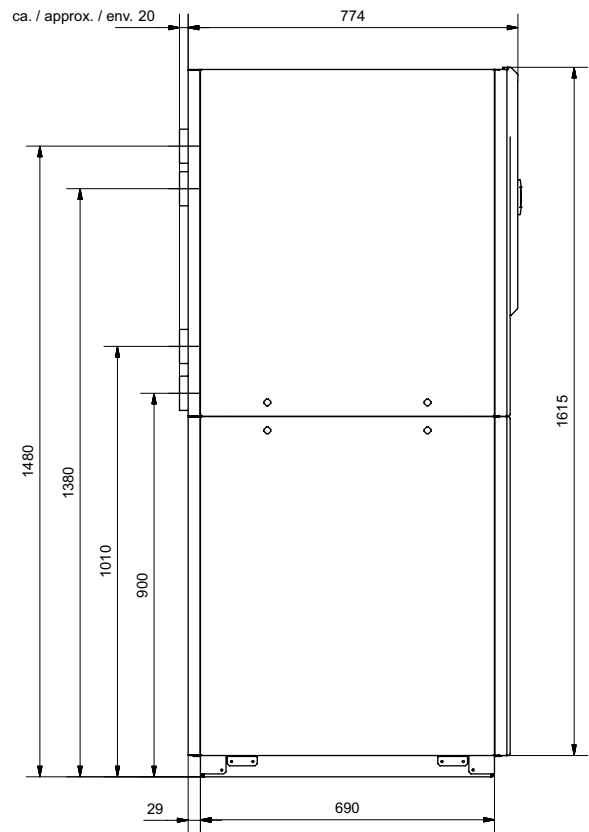
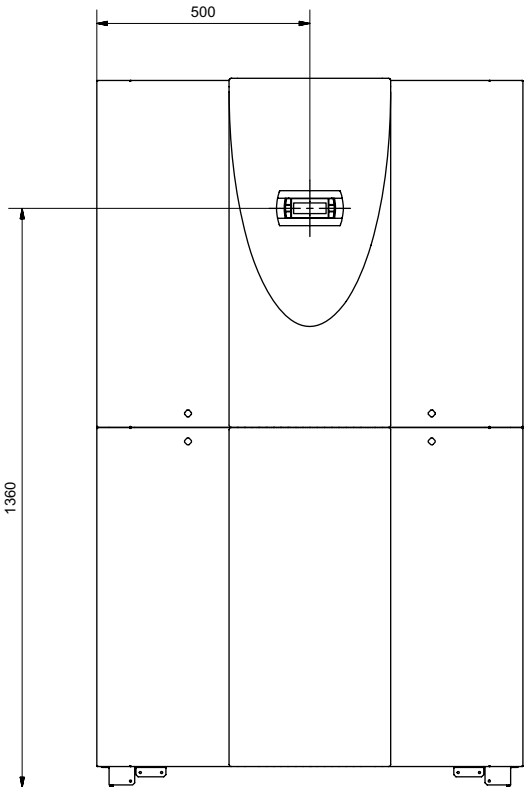
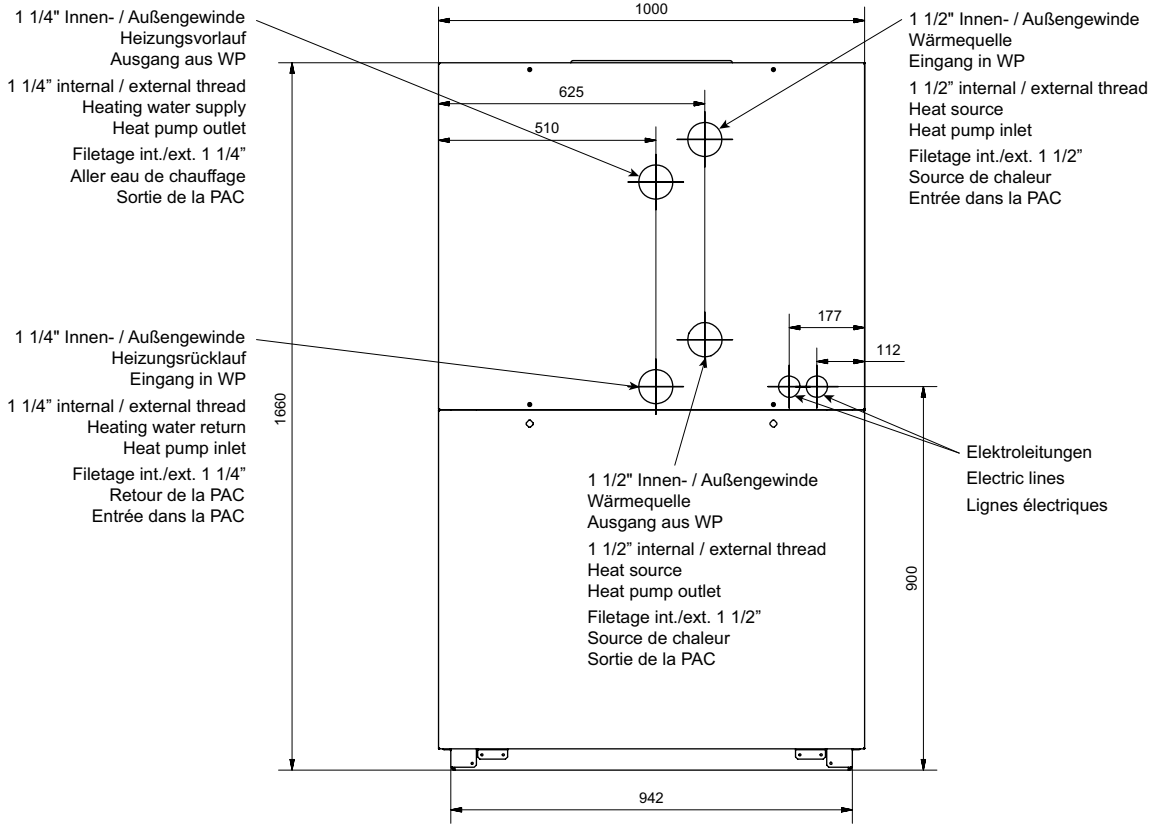

Anhang · Appendix · Annexes

1.2 Maßbild / Dimensioned drawing / Schéma coté SI 37TE

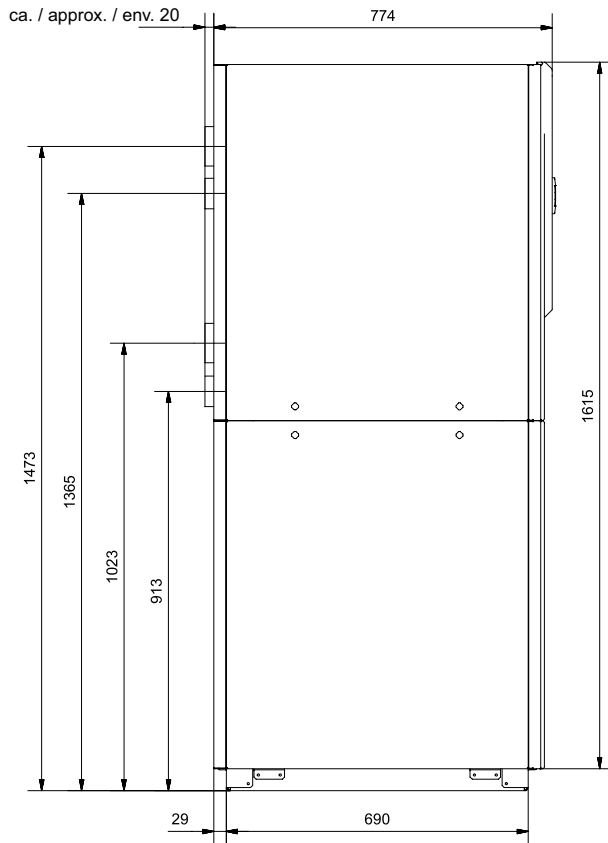
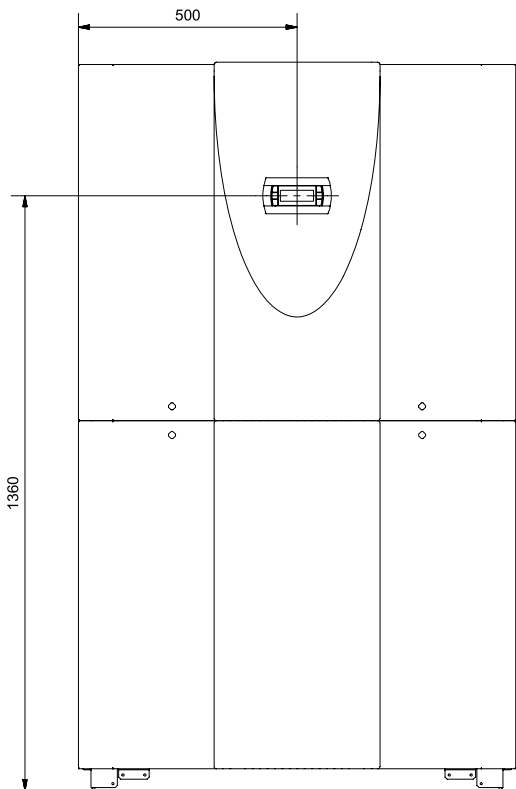
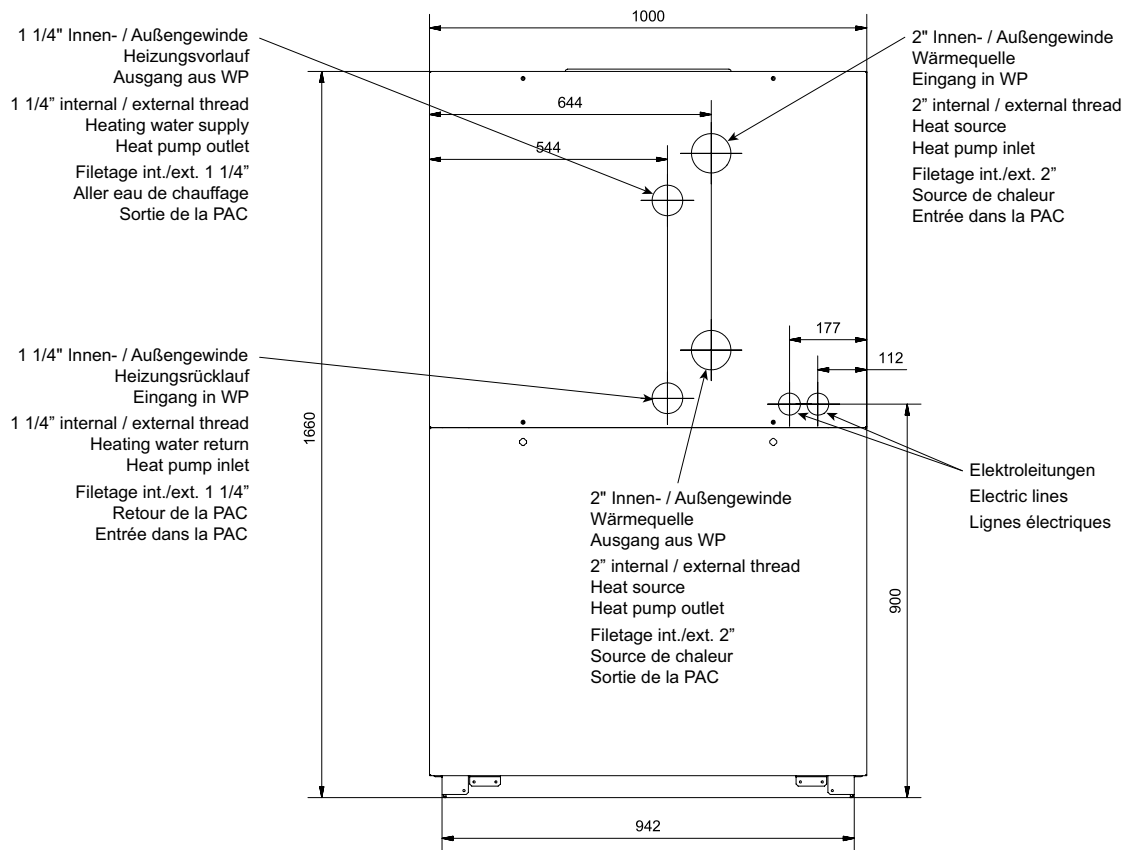

Anhang - Appendix - Annexes

2 Diagramme / Schematics / Diagrammes

2.1 Kennlinien / Schematics / Courbes caractéristiques SI 24TE

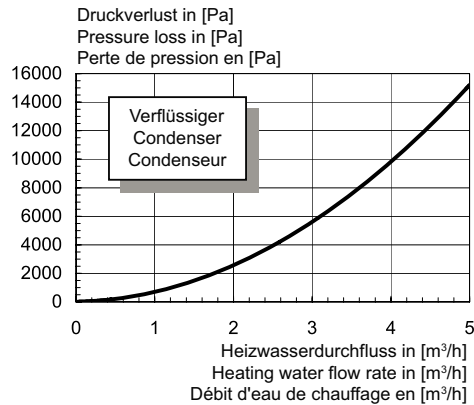
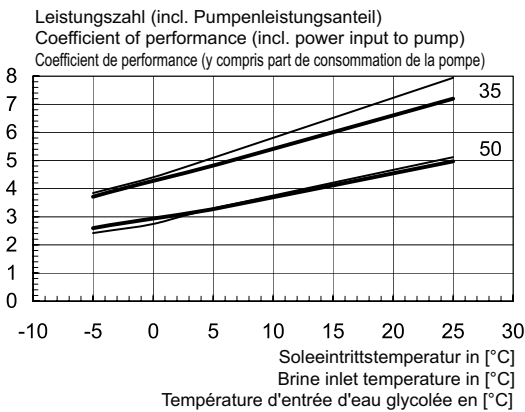
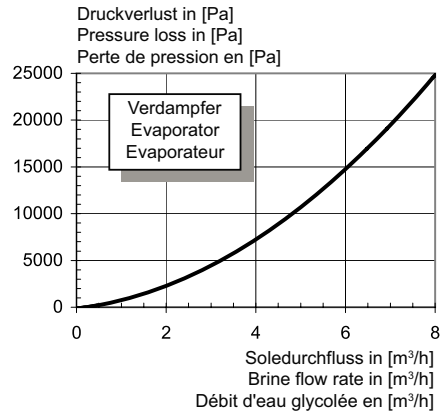
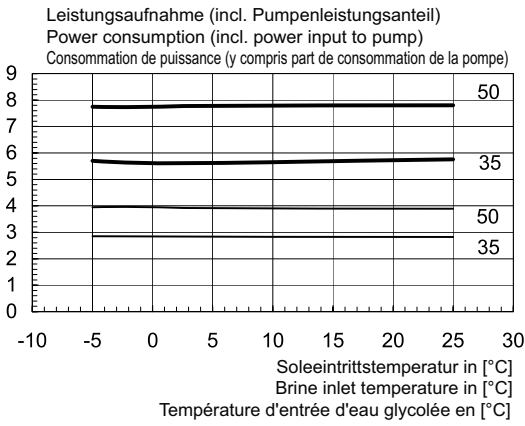
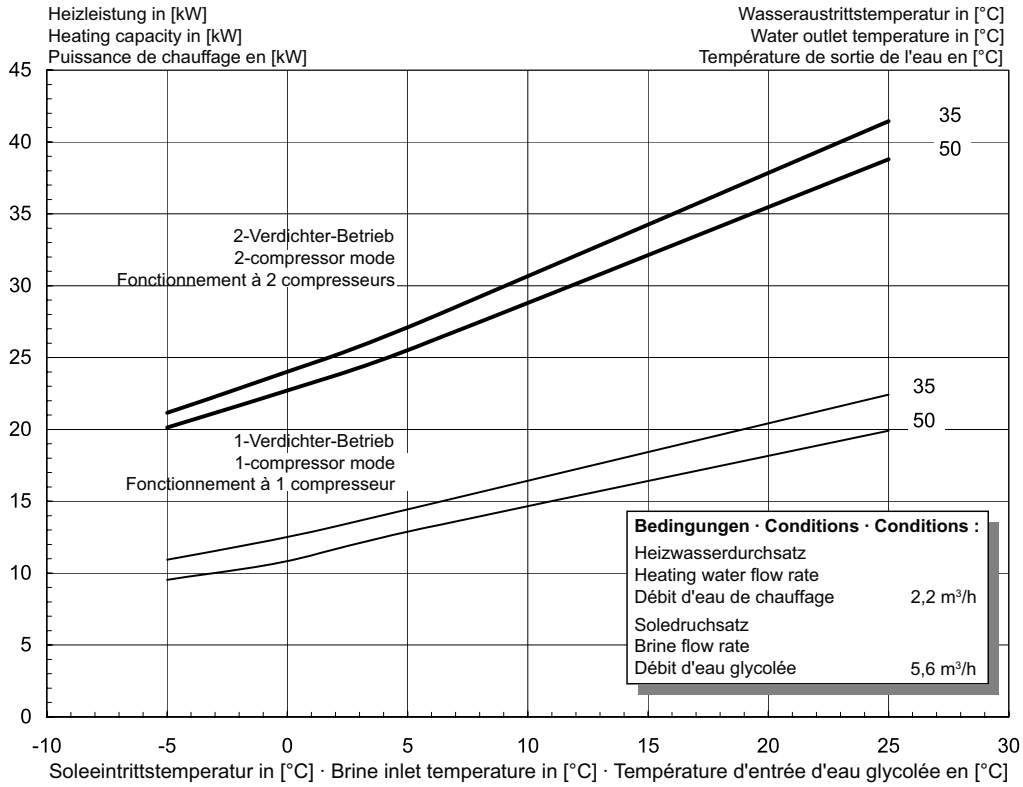

Anhang · Appendix · Annexes

2.2 Kennlinien / Schematics / Courbes caractéristiques SI 37TE

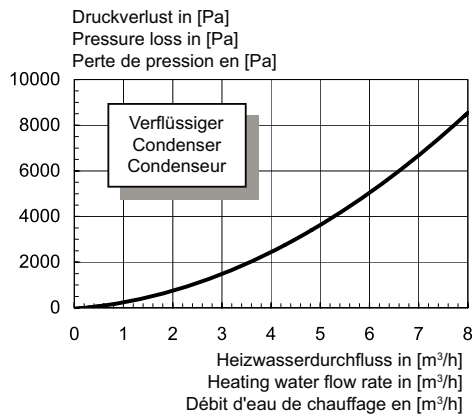
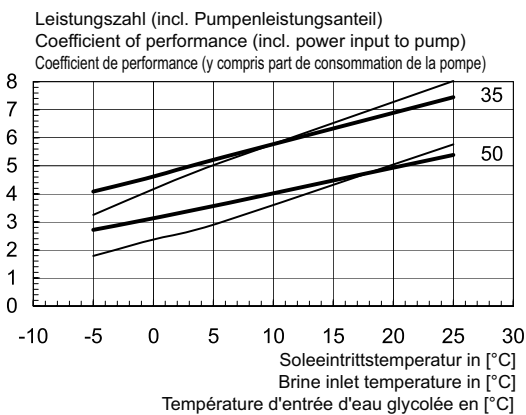
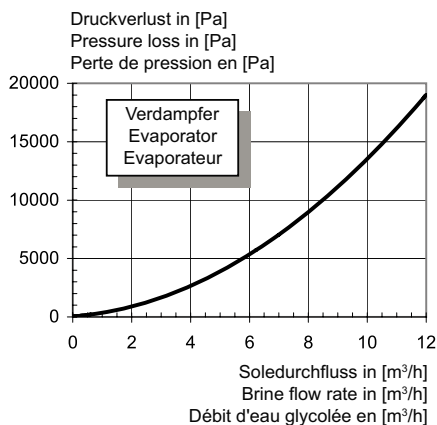
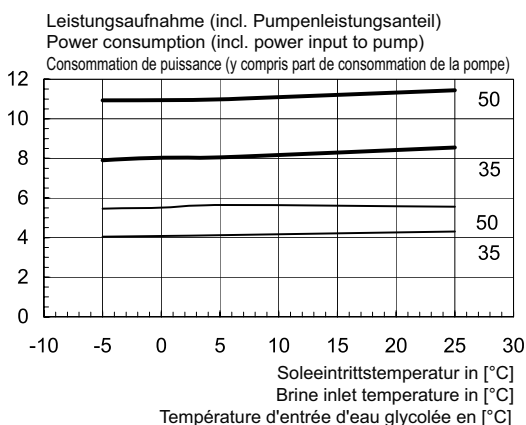
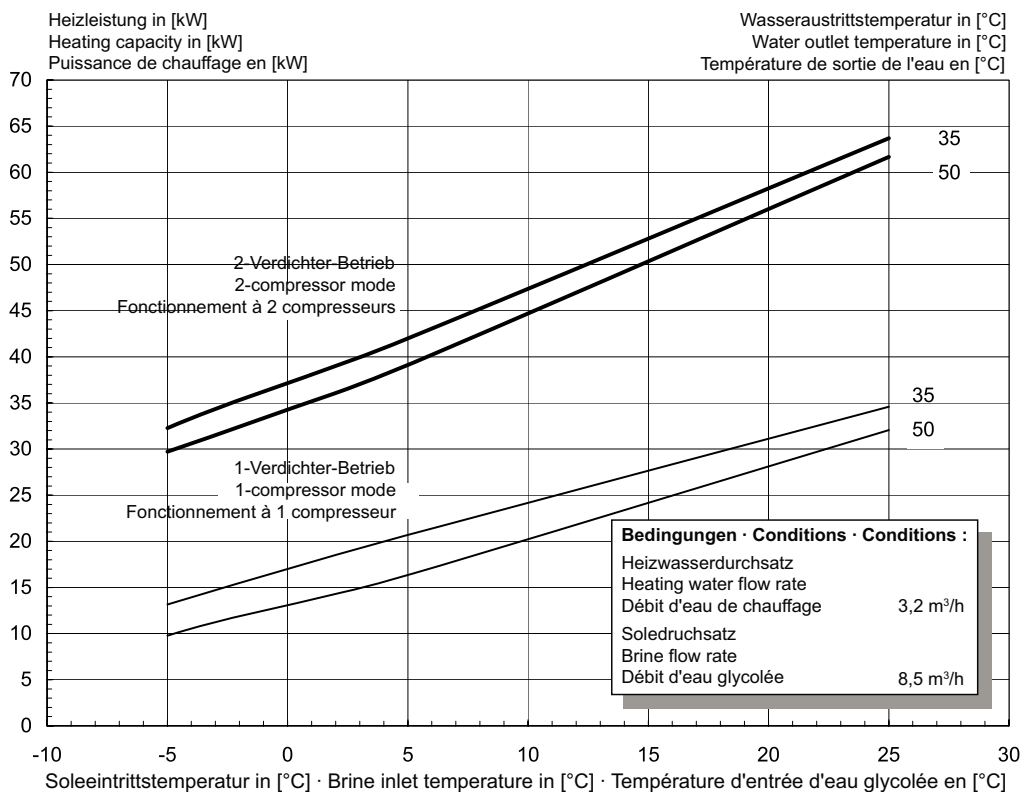

3 Stromlaufpläne / Wiring diagrams / Schémas électriques

3.1 Steuerung / Control / Commande

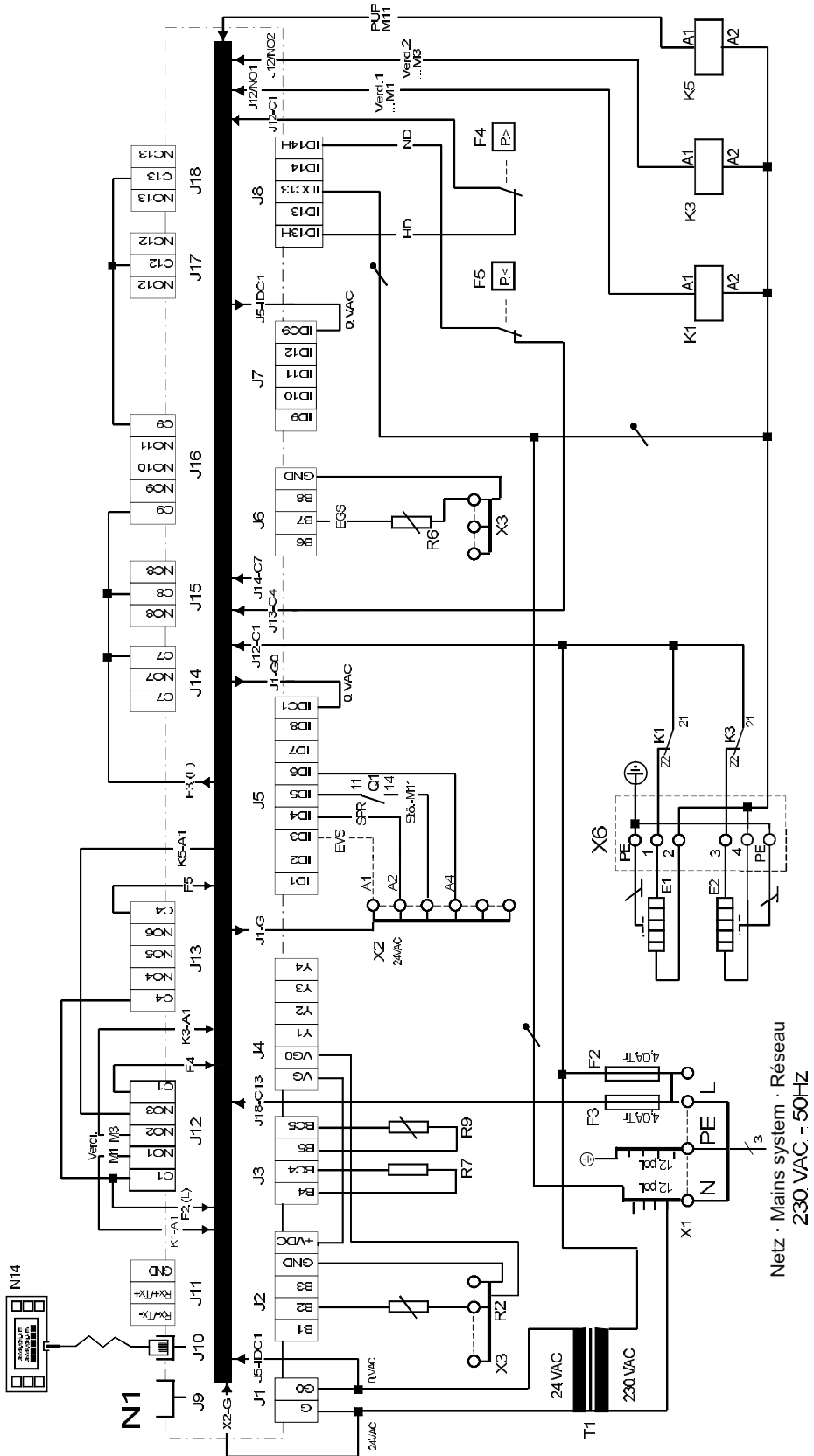

Anhang · Appendix · Annexes

3.2 Last / Load / Charge

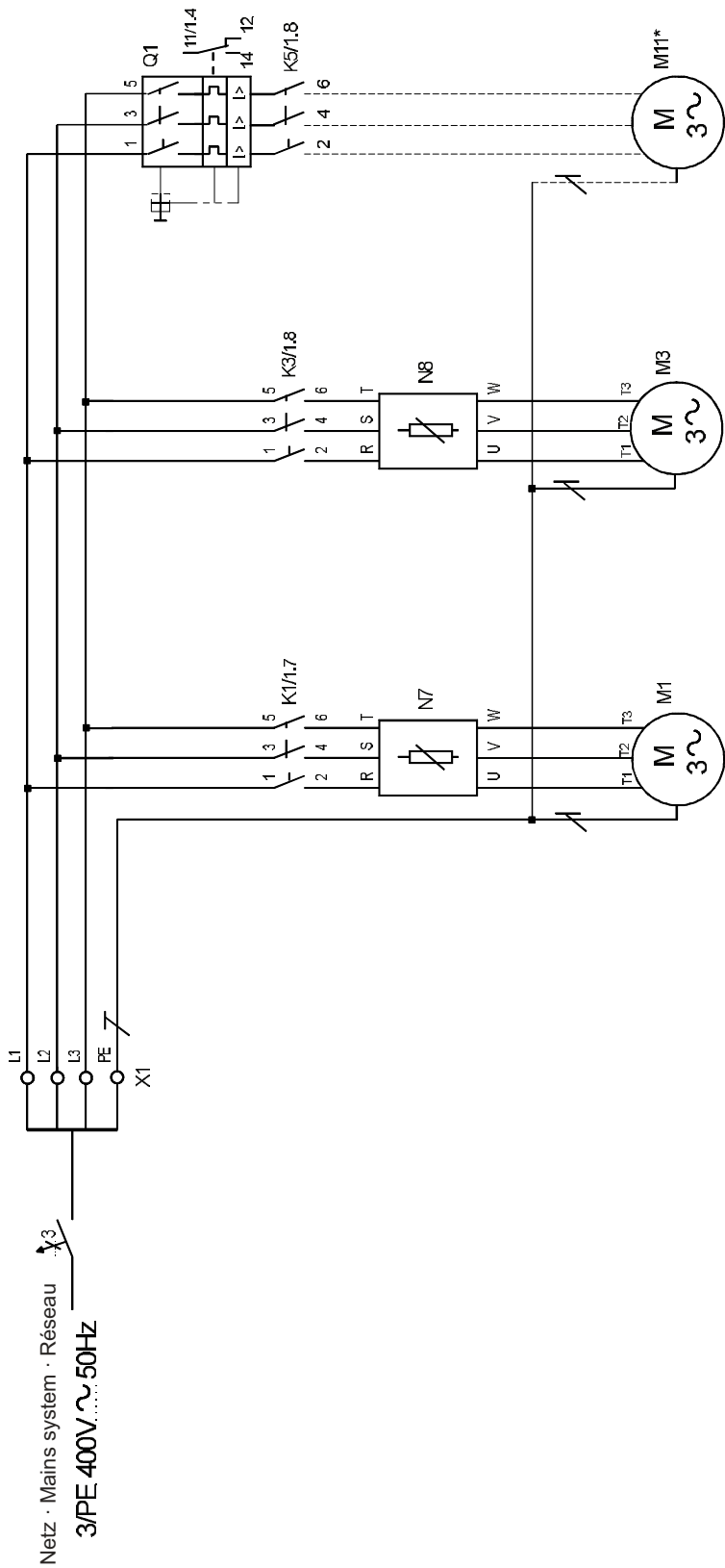

* M11 ist optional
M11 is optional
M11 en option

3.3 Anschlussplan / Terminal diagram / Schéma de branchement

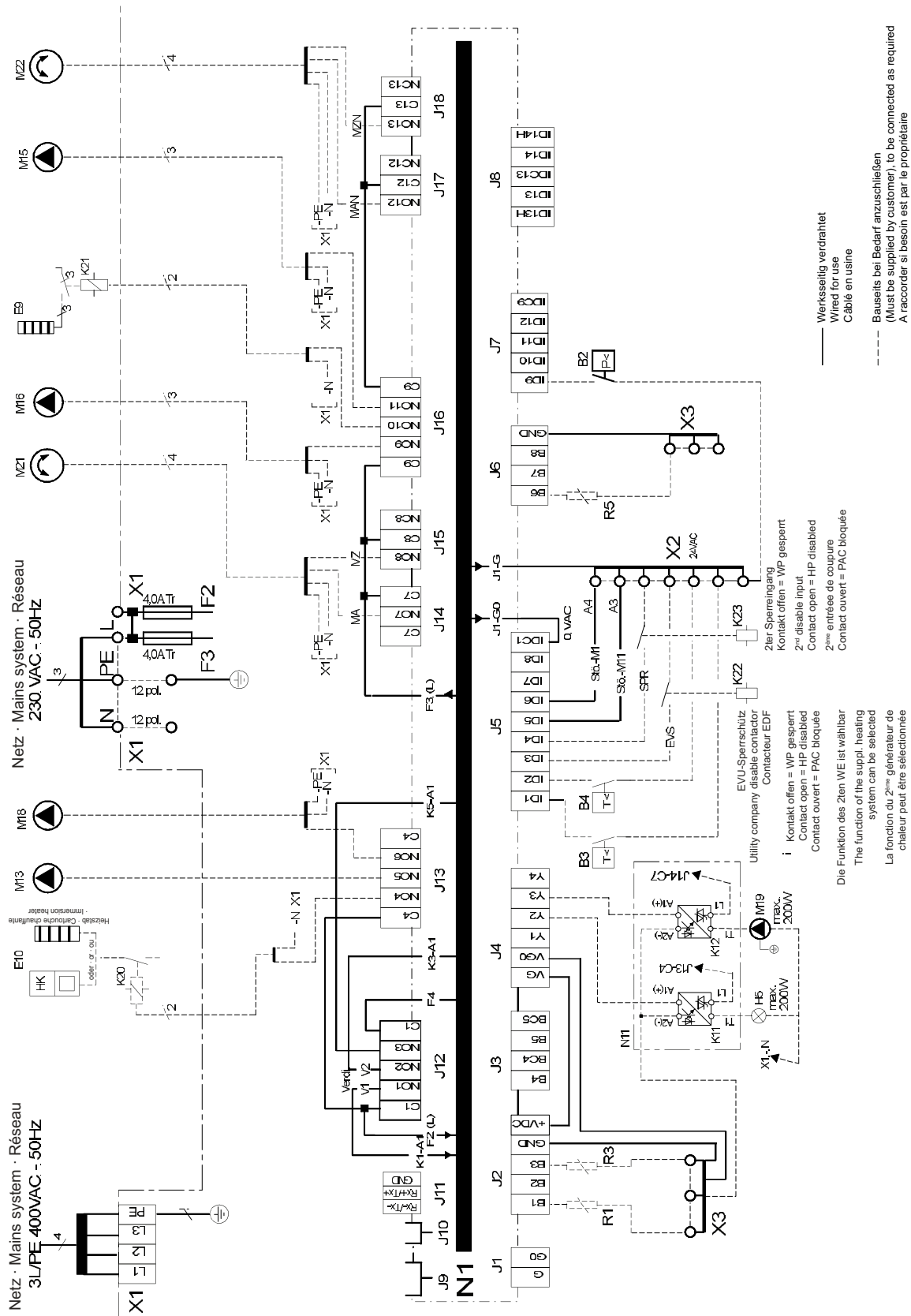

3.4 Legende / Legend / Légende







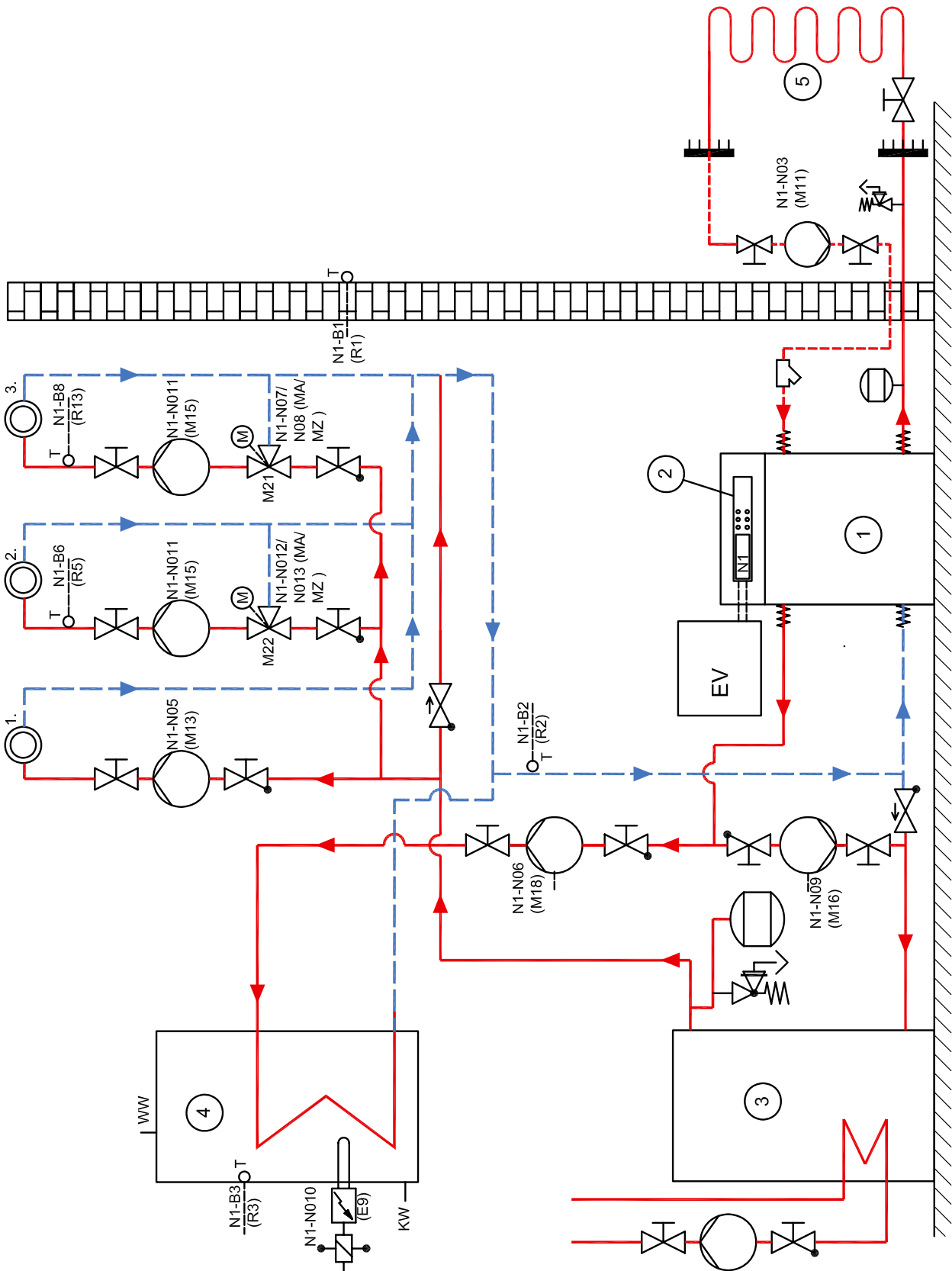



A1	Drahtbrücke, muss bei Einsatz eines EVU-Spererschützes entfernt werden	Wire jumper, must be removed when an A2 utility blocking contactor is installed	Enlever le cavalier à fil si un contacteur de coupure du fournisseur d'énergie est utilisé
A2	Drahtbrücke, muss bei Verwendung des 2. Sperreinganges entfernt werden	Wire jumper, must be removed if 2nd disable input is used	Retirer le cavalier à fil lors de l'utilisation de la deuxième entrée de coupure
A4	Drahtbrücke, muss bei Einsatz eines Motorschutzkontaktes, für den Verdichter, entfernt werden	Wire jumper, must be removed when a motor protection contact is used for the compressor	Retirer le cavalier à fil si utilisation d'un contact de disjoncteur de moteur, pour le compresseur
B2*	Pressostat Niederdruck-Sole	Pressostat low pressure, brine	Pressostat basse pression eau glycolée
B3*	Thermostat Warmwasser (alternativ zu R3)	Thermostat, hot water (as an alternative to R3)	Thermostat eau chaude (alternative R3)
B4*	Thermostat Schwimmbadwasser	Thermostat, swimming pool water	Thermostat eau de piscine
E9*	Tauchheizkörper Warmwasser	Immersion heater, hot water	Thermoplongeur eau chaude
E10*	2. Wärmeerzeuger (Heizkessel oder Elektr.-Heizstab)	Suppl. heating system (boiler or electr. heating system)	2ème générateur de chaleur (chaudière ou cartouche chauffante électr.)
F2	Lastsicherung für N1-Relaisausgänge an J12 und J13 4,0 ATr	Load fuse for N1 relay outputs across J12 and J13 4,0 A slow-acting	Coupe-circuit de la charge pour sorties de relais en J12 et J13 4,0 ATr
F3	Lastsicherung für N1-Relaisausgänge an J15 bis J18 4,0 ATr	Load fuse for N1 relay outputs across J15 to J18 4,0 A slow-acting	Coupe-circuit de la charge pour sorties de relais en J15 jusqu'à J18 4,0 ATr
F4	Pressostat Hochdruck	Pressostat, high pressure	Pressostat haute pression
F5	Pressostat Niederdruck	Pressostat, low pressure	Pressostat basse pression
H5*	Leuchte Störferrnanzeige	Lamp, remote fault indicator	Lampe témoin télédétection des pannes
J1...J18	Klemmensteckverbinder an N1	Terminal connector at N1	Connecteur à fiches pour borne de connexion en N1
K1	Schütz Verdichter 1	Contactor, compressor 1	Contacteur compresseur 1
K3	Schütz Verdichter 2	Contactor, compressor 2	Contacteur compresseur 2
K5	Schütz Primärpumpe (PUP)	Contactor for primary pump (PUP)	Contacteur pompe primaire (PUP)
K11*	Elektron. Relais für H5 (auf N11)	Electron. relay for H5 (at N11)	Relais électron. pour H5 (sur N11)
K12*	Elektron. Relais für M19 (auf N11)	Electron. relay for M19 (at N11)	Relais électron. pour M19 (sur N11)
K20*	Schütz 2. Wärmeerzeuger	Contactor, suppl. heating system	Contacteur 2ème générateur de chaleur
K21*	Schütz Flanschheizkörper Warmwasser	Contactor for elect. flange heater for domestic hot water	Contacteur corps de chauffe à bride élect. eau chaude
K22*	EVU-Spererschütz (siehe A1)	Utility company disable contactor (see A1)	Contacteur EDF (voir A1)
K23*	SPR-Hilfsschütz (siehe A2)	SPR auxiliary contactor (see A2)	Relais auxiliaire „SPR“ (voir A2)
M1	Verdichter 1	Compressor 1	Compresseur 1
M3	Verdichter 2	Compressor 2	Compresseur 2
M11*	Primärpumpe	Primary pump	Pompe primaire
M13*	Heizungsumwälzpumpe	Heating circulating pump	Circulateur de chauffage
M15*	Heizungsumwälzpumpe 2. Heizkreis	Heating circulating pump for heating circuit 2	Circulateur de chauffage 2ème circuit de chauffage
M16*	Zusatzumwälzpumpe	Suppl. circulating pump	Circulateur d'appoint
M18*	Warmwasserumwälzpumpe	Hot water circulating pump	Circulateur d'eau chaude
M19*	Schwimmbadwasserumwälzpumpe	Swimming pool circulating pump	Circulateur d'eau de piscine
M21*	Mischer Hauptkreis	Mixer, principal circuit	Mélangeur circuit principal
M22*	Mischer 2. Heizkreis	Mixer, heating circuit 2	Mélangeur 2ème circuit de chauffage
N1	Wärmepumpenregler	Heat pump controller	Régulateur de pompe à chaleur
N7	Sanftanlaufsteuerung Verd. 1	Soft start control for compr. 1	Commande de démarrage progressif compr. 1
N8	Sanftanlaufsteuerung Verd. 2	Soft start control for compr. 2	Commande de démarrage progressif compr. 2
N11*	Relaisbaugruppe	Relay module	Boîtier de relais
N14	Bedienteil	Operating element	Commande
Q1	Motorschutz M11	Motor protection feature M11	Protection moteur M11
R1	Außenfühler	External sensor	Sonde extérieure
R2	Rücklauffühler	Return sensor	Sonde retour chauffage
R3*	Warmwasserfühler (alternativ zum Warmwasserthermostat)	Hot water sensor (as an alternative to hot water thermostat)	Sonde eau chaude (alternative au thermostat eau chaude)
R5*	Fühler für 2. Heizkreis	Sensor for heating circuit 2	Sonde pour 2ème circuit de chauffage
R6	Eingefrierschutzfühler	Freeze protection sensor	Sonde antigel
R7	Kodierwiderstand 8k2	Coding resistor 8k2	Résistance avec code des couleurs 8,2 kOhm
R9	Vorlauffühler	Flow sensor	Sonde aller
T1	Sicherheitstrenntransformator 230/24 VAC-28VA	Safety isolating transformer 230/24 VAC-28VA	Transformateur de coupure de sécurité 230/24 VAC-28VA
X1	Klemmenleiste Netz-Last 3L/PE-400VAC 50Hz / -Steuerung L/N/PE-230VAC 50Hz / Sicherungen / N- und PE-Verteiler	Terminal strip for mains load 3L/PE 400VAC-50Hz / control L/N/PE-230VAC-50Hz / fuses / N and PE terminal blocks	Bornier charge réseau 3L/PE400VAC-50Hz / commande L/N/PE-230VAC-50Hz / fusibles / distr. N et PE
X2	Klemmenleiste 24 VAC-Verteiler	Terminal strip 24 VAC-terminal block	Bornier 24 VAC - répartiteur
X3	Klemmenleiste GND-Verteiler für Sensoren	Terminal strip GND terminal block for sensors	Bornier GND - répartiteur pour sondes
X6	Anschlussdose Kurbelwellenheizung	Outlet for crankcase heater	Prise chauffage à carter compresseur
Abkürzungen			
EVS	EVU-Sperreingang	Utility company disable input	Entrée de coupure courant du fournisseur de courant
SPR	Zusätzlicher Sperreingang	Supplementary disable input	Entrée de coupure complémentaire
MA	Mischer AUF	Mixer OPEN	Mélangeur OUVERT
MZ	Mischer ZU	Mixer CLOSED	Mélangeur FERME
*	Bauteile sind bauseits beizustellen, bzw. als Zubehör erhältlich	Components to be supplied by the customer, available as accessories	Pièces fournies par le client (disponibles comme accessoires)
Abbreviations:			
Abréviations :			

4 Hydraulisches Prinzipschema / Hydraulic block diagrams / Schéma hydraulique

4.1 Darstellung / Schematic view / Représentation schématique



4.2 Legende / Legend / Légende

	Rückschlagventil	Check valve	Clapet anti-retour
	Absperrventil	Shutoff valve	Robinet d'arrêt
	Dreiwegemischer	Three-way mixer	Mélangeur 3 voies
	Umwälzpumpe	Circulating pump	Circulateur
	Ausdehnungsgefäß	Expansion vessel	Vase d'expansion
	Absperrventil mit Rückschlagventil	Shutoff valve with check valve	Robinet d'arrêt avec clapet anti-retour
	Sicherheitsventilkombination	Safety valve combination	Groupe de valves de sécurité
	Wärmeverbraucher	Heat consumer	Consommateur de chaleur
	Temperaturfühler	Temperature sensor	Sonde de température
	Flexibler Anschlussschlauch	Flexible connection hose	Tuyau de raccord flexible
①	Sole/Wasser-Wärmepumpe	Brine-to-water heat pump	Pompe à chaleur eau glycolée/eau
②	Wärmepumpenmanager	Heat pump manager	Gestionnaire de pompe à chaleur
③	Pufferspeicher	Buffer tank	Réservoir tampon
④	Warmwasserspeicher	Hot water cylinder	Ballon d'eau chaude
⑤	Wärmequelle	Heat source	Source de chaleur
E9	Tauchheizkörper Warmwasser	Immersion heater hot water	électrique eau chaude
M11	Primärumschälzpumpe	Primary circulating pump	Circulateur primaire
M13	Heizungsumwälzpumpe	Heat circulating pump	Circulateur de chauffage
M15	Heizungsumwälzpumpe 2. Heizkreis	Heat circulating pump of heating circuit 2	Circulateur de chauffage 2e circuit de chauffage
M16	Zusatzumwälzpumpe	Auxiliary circulating pump	Circulateur supplémentaire
M18	Warmwasserumwälzpumpe	Hot water circulating pump	Circulateur d'eau chaude
M21	Mischer 3. Heizkreis	Mixer for heating circuit 3	Mélangeur 3e circuit de chauffage
M22	Mischer 2. Heizkreis	Mixer for heating circuit 2	Mélangeur 2e circuit de chauffage
N1	Regeleinheit	Control unit	Unité de régulation
R1	Außenwandfühler	External wall sensor	Sonde de paroi extérieure
R2	Rücklauffühler	Return flow sensor	Sonde retour chauffage
R3	Warmwasserfühler	Hot water sensor	Sonde d'eau chaude
R5	Fühler 2. Heizkreis	Sensor for heating circuit 2	Sonde 2e circuit de chauffage
R13	Fühler 3. Heizkreis	Sensor for heating circuit 3	Sonde 3e circuit de chauffage
EV	Elektroverteilung	Electrical distribution system	Distributeur courant électrique
KW	Kaltwasser	Cold water	Eau froide
WW	Warmwasser	Hot water	Eau chaude

5 Konformitätserklärung / Declaration of Conformity / Déclaration de conformité



EG - Konformitätserklärung EC Declaration of Conformity Déclaration de conformité CE



Der Unterzeichnete
The undersigned
La société soussignée,

Glen Dimplex Deutschland GmbH
Geschäftsbereich Dimplex
Am Goldenen Feld 18
D - 95326 Kulmbach

bestätigt, dass das (die) nachfolgend be-
zeichnete(n) Gerät(e) aufgrund seiner (ihrer)
Konzipierung und Bauart sowie in der von
uns in Verkehr gebrachten Ausführung den
einschlägigen grundlegenden Anforderungen
der EG-Richtlinien entspricht (entsprechen).

hereby confirm that the design and con-
struction of the product(s) listed below,
in the version(s) placed on the market by
us, conform to the relevant requirements
of the applicable EC directives.

certifie que l'appareil / les appareils ci-
après, par leur conception et leur mode de
construction ainsi que par la définition
technique avec laquelle il(s) sont mis en
circulation par notre société, est / sont
conforme(s) aux directives fondamentales
CEE afférentes.

Bei einer nicht mit uns abgestimmten
Änderung des (der) Gerät(e)s verliert
diese Erklärung ihre Gültigkeit.

This declaration becomes invalidated
if any modifications are made to
the product(s) without our prior
authorisation.

Ce certificat perd sa validité pour tout
appareil modifié sans notre consentement.

Bezeichnung / Designation / Désignation

EG - Richtlinien / EC Directives / Directives CEE

Sole/Wasser-Wärmepumpen

für Innenaufstellung mit R404A

EG- Niederspannungsrichtlinie / EC Low Voltage Directive /
Directive CEE relative à la basse tension (73/23/EWG)

Brine-to-water heat pumps

for indoor installation, containing R404A

EG-EMV-Richtlinie / EC EMC Directive / Directive CEE
relative à la compatibilité électromagnétique (89/336/EWG)

Pompes à chaleur eau glycolée/eau

pour installation intérieure avec R404A

Druckgeräterichtlinie / Pressure Equipment Directive /
Directive CEE relative aux appareils sous pression (97/23/EG)

Typ(e):

Harmonisierte EN / Harmonized EB Standards / Normes EN harmonisées:

SI 24TE

EN 255:1997

SI 37TE

EN 378:2000

DIN 8901

DIN EN 60335-1 (VDE 0700 T1):2005-07

DIN EN 60335-2-40 (VDE 0700 T40):2004-03

DIN EN 55014-1 (VDE 0875 T14-1):2003-09

DIN EN 55014-2 (VDE 0875 T14-2):2002-08

DIN EN 61000-3-2 (VDE 0838 T2):2001-12

DIN EN 61000-3-3 (VDE 0838 T3):2002-05

EN 60335-1:2002+A11:2004+A1:2004

EN 60335-2-40:2003

EN 55014-1:2000+A1:2001+A2:2002

EN 55014-2:1997+A1:2001

EN 61000-3-2:2000

EN 61000-3-3:1995+Corr.:1997+A1:2001

Nationale Richtlinien / National Directives / Directives nationales

D

A

CH

VBG20

SVTI

Kulmbach, 28.09.2006

CE09W01G.doc

Wolfgang Weinhold
Geschäftsführer / Managing Director

Andreas Tilch
Spartenleiter / Head of business unit

