

## Water-to-water heat pump with stainless steel coil heat exchanger

Max. flow temperature: 58 °C  
 Casing colour: White (similar to RAL 9003)  
 Brown-red design screen (RAL 3011)

Heat pump for heating purposes for indoor installation with integrated WPM 2007 plus controller. The control panel is integrated into a brown-red design screen and can also be used as wired remote control using the wall mounting set (special accessories MS PGD). Variable connection options for the ground water and heating connections on the rear wall of the casing. Sound-optimised through insulated metal casing and double vibration-isolated compressor. Economiser for high coefficients of performance (COP). Integrated corrosion-proof and freeze-proof stainless steel coil evaporator. Universal design with optional domestic hot water preparation and flexible expansion possibilities for:

- Bivalent or bivalent-renewable operating mode
- Distribution systems with unmixed and mixed heating circuits

Integrated soft starter (from WI 14), integrated flow rate switch and load contactor for a well water pump; flow sensor, return sensor, external sensor (standard NTC-2) and dirt filter for ground water included in the scope of supply.

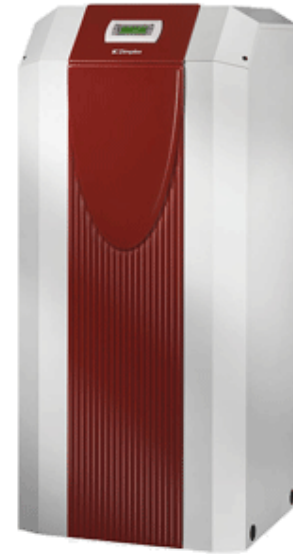

### Technical data

#### Dimplex Water-to-water heat pump with stainless steel coil heat exchanger (Low temperature)

Order reference	WI 27TE
Casing colour	White (similar to RAL 9003)
Max. flow temperature	58 °C
Lower operating limit heat source (heating operation) / Upper operating limit heat source (heating operation)	7 to 25 °C
Heat output 1 compressor at W10/W35 / COP W10/W35	26,1 kW / 4,9
Heat output with 1 compressor / COP W10/W45	26 kW / 4,1
Nominal power consumption according to EN 14511 at W10/W35	5,29 kW
Sound power level device	59 dB (A)
Refrigerant / Amount of refrigerant	R407C / 4,5 kg
Max. heating water flow rate / Pressure drop	4,5 m³/h / 36000 Pa
Heat source flow (min.)	7 m³/h
Dimensions (W x H x D)**	650 x 1445 x 575 mm
Weight	259 kg
Connection voltage	3/N/PE ~400 V, 50 Hz
Starting current with soft starter	29 A
Fuse protection	C 20 A
Connection heating	1 ¼ inch
Heat source connection	1 ½ inch

\*Heat output and coefficient of performance (COP) according to EN 14511 at W10/W35 (W10 = ground water inlet temp. +10 °C, W35 = heating water outlet temp. +35 °C)

\*\*Please note that additional space is required for pipe connections, operation and maintenance.

Description	Order ref.	Article number	Sample item	Item	Price
<b>Heat pumps</b>					
Water-to-water heat pump with stainless steel coil heat exchanger	WI 27TE	353160	1		
Elasticated sound insulation underlay strips	SYL 250	352260			
DN 32 double-sphere rubber expansion joint	KOMP 32	362060			
DN 32 dirt trap	SMF 32	362140			
<b>Heat source accessories</b>					
Plate heat exchanger for SI 30	WTE 30	358410			
<b>Hydraulic accessories</b>					
Free-standing buffer tank 200 l	PSW 200	339830	1		
Immersion heater 4.5 kW; ~230 V	CTHK 630	363610			
Immersion heater 2.0 kW; ~230 V	CTHK 631	336180			
Immersion heater 2.9 kW; ~400 V	CTHK 632	335910			
Immersion heater 4.5 kW; ~400 V	CTHK 633	322140			
Immersion heater 6.0 kW; ~400 V	CTHK 634	322150			
Universal buffer tank (500 l)*	PSW 500	339210			
Dual differential pressureless manifold	DDV 32	348450	1		
Circulating pump for heating water	UP 70-32	354020	1		
Domestic hot water module/unmixed heating circuit module	WWM 25	346600	1		
Electronically regulated wet running pump (0-10 V) with coupling relay	UPE 70-25	362790	1		
Manifold bar	VTB 25	339870			
Mixed heating circuit module with temperature sensor	MMH 25	348640			
Ready-for-use DN 32 stainless steel Wellflex pipe	VSE 32-50	362520			
Ready-for-use DN 32 stainless steel Wellflex pipe	VSE 32-100	362530			
Ready-for-use DN 32 stainless steel Wellflex pipe	VSE 32-150	362540			
Ready-for-use DN 32 stainless steel Wellflex pipe	VSE 32-200	362550			
Ready-for-use DN 32 stainless steel Wellflex pipe	VSE 32-300	362560			
<b>Heating accessories</b>					
Fan convectors heating 800 W	SRX 080M	359080			
Fan convectors heating 1200 W	SRX 120M	359090			
Fan convectors heating 1400 W	SRX 140M	359100			
Fan convectors heating 1800 W	SRX 180M	359110			
<b>DHW preparation accessories</b>					
Domestic hot water cylinder (500 l) with temperature sensor	WWSP 900	339220	1		
Flange heater for domestic hot water	FLH 60	338060			
Flange heater for domestic hot water	FLHU 70	338070	1		
Flange heater for domestic hot water	FLH 90	366130			
FLH 25M flange heater	FLH 25M	349430			
Safety valve combination	SVK 852	326660			
Combo tank for heating and domestic hot water preparation with central flow*	PWD 750	349100			
Combo tank for heating and domestic hot water preparation with central flow*	PWD 900	362860			
Pump unit DN 32 for direct connection of the domestic hot water cylinder	WPG 32	356040	1		
Circulating pump for heating water	UP 70-32	354020	1		
<b>Control accessories</b>					
Extension for an Ethernet network connection	NWPM	356960			
Extension for a KNX/EIB bus connection	EWPM	356970			
Extension for a Modbus connection	LWPM 410	339410			
Interface card for HPM for connection of Smart RTC and WPM Econ PK/PKS 14/25 Econ	RWPM	363370			
Swimming pool/remote fault indicator relay module	RBG WPM	339700			
MS PGD wall mounting kit	MS PGD	353810			
Remote control for WPM 2006/2007/EconPlus/R*	AP PGD	356570			
External temperature sensor with casing	FG 3115	336620			
Temperature sensor NTC-10 with metal sleeve	NTC-10M	363600			
Thermostat for heating and domestic hot water	KRRV 003	322070			
<b>Accessories for passive cooling</b>					
Three-way distribution valve	DWU 40	347770			
Two-way isolation valve	ZWU 32	348950			

Description	Order ref.	Article number	Sample item	Item	Price
Plate heat exchanger, copper-soldered	WTU 50	362370			
Plate heat exchanger for SIH 20	WTE 20	358400			
Plate heat exchanger for SI 30	WTE 30	358410			
<b>Control accessories (cooling)</b>					
Passive cooling controller*	WPM Econ PK	360000			
Room climate station for temperature and humidity measurement	RKS WPM	342220			
Room temperature controller heating/cooling*	RTK 601U	355610			
Room temperature controller heating/cooling	RTK 602U	355620			
Dew point monitor*	TPW WPM	350970			

\* Other specific accessories available / required

**Important information:**

The combination of the components and the quantities indicated represent a non-binding sample system, which needs to be tested and individually adapted as required. Pump dimensioning must be reviewed according to the pressure loss of the system and the minimum heating water flow rate of the heat pump.

**Note:**

The given hydraulic integration schematic is a schematic representation of the key components and serves as an aid for planning your customized system. The current status is available at all times under [www.dimplex.de/nc/en/professional/online-planner/hydraulic-integrations.html](http://www.dimplex.de/nc/en/professional/online-planner/hydraulic-integrations.html). It does not contain all the required safety devices, the components needed to maintain constant pressure, or any other additional valves which may be required for maintenance and service work as stipulated by EN 12828. The heat pump manager settings and any external regulation system which may be connected must be adapted to the present integration diagram. Software updates may be required!

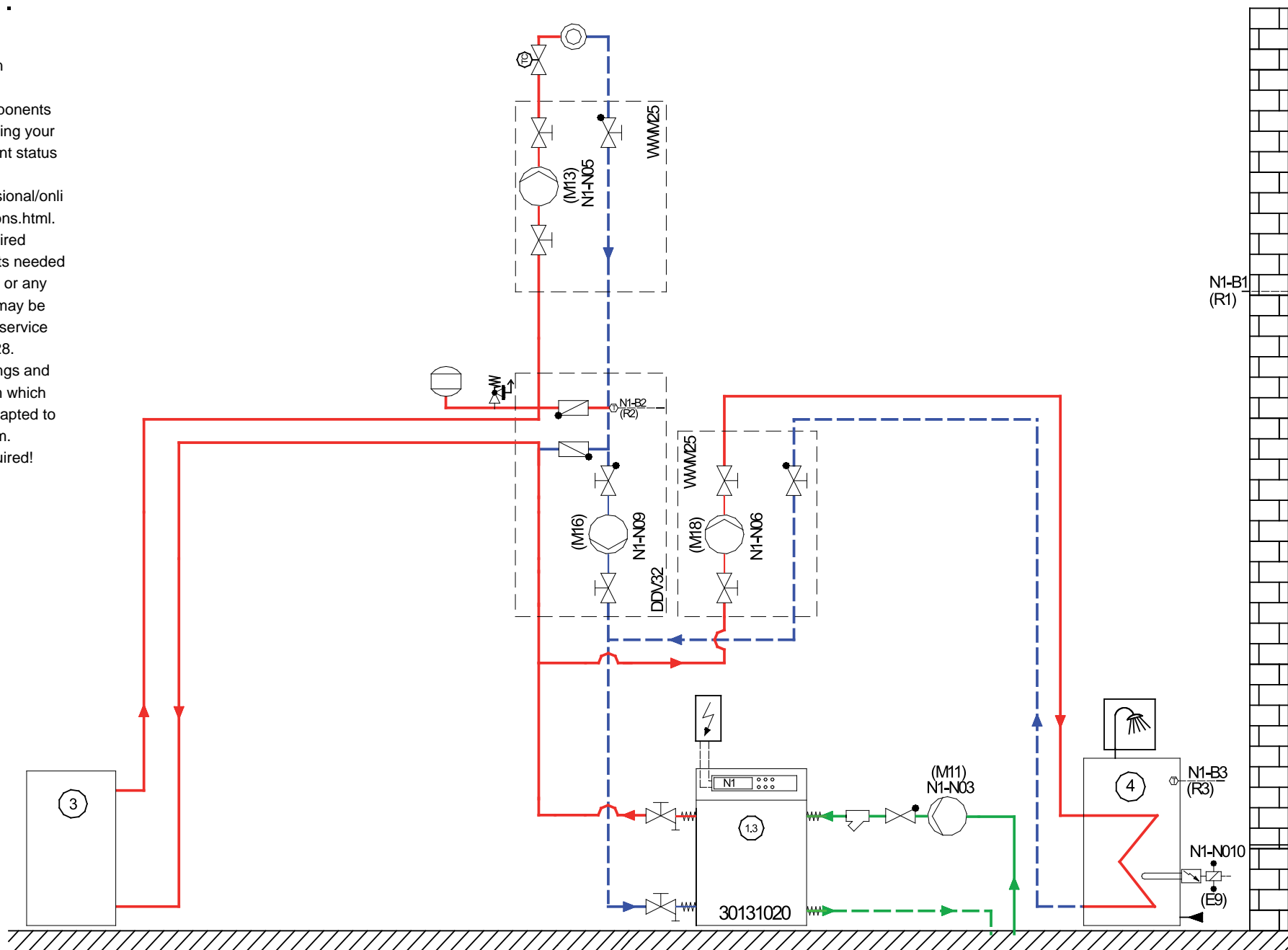

## System description:

- In the case of a ground water heat source, it must be ensured that the required cold water flow is permanently available with a minimum temperature of 7°C. The required water quality must be maintained additionally. Water quality Approval of local water authorities for use of ground water must be obtained!
- A buffer tank connected in series is recommended for heat pump heating systems, to ensure the minimum heat pump runtime of 6 minutes for all operating statuses.
- In monovalent systems, the output of the heat pump covers the heat consumption of the building throughout the whole year - 100% - by itself. High heat output during shut-off times and domestic hot water preparation is supplied by the heat pump. Normally, only brine-to-water and water-to-water heat pumps are operated in monovalent mode.
- The heat exchanger in the hot water cylinder must transfer the maximum heat output at the maximum heat source temperature. In systems with high hot water consumption (multiple dwellings, industrial applications) the cylinder must be set to the maximum peak demand while taking the shut-off times into account. The maximum heat output and the maximum heating water flow must be adhered to!
- The contactor for the flange heater (E9) in the hot water cylinder should be dimensioned according to the output and must be supplied by the customer. It is controlled (230 V AC) by the heat pump manager via terminals X1/N and J16/NO10. The maximum heat output of the heat pump and the water flow are to be observed.
- The dual differential pressureless manifold ensures that the required minimum water flow rate is maintained, independent of both the number of open heating circuits and of how the system is used. Hydraulic isolation is carried out using two connections between flow and return; each connection is fitted with a check valve. The characteristic curve of the pump in the consumer circuit must be set in such a way that a maximum spread of 10 Kelvin is not exceeded, in order to prevent unnecessary surging of the heat pump. Electronically regulated pumps must be operated at a constant pressure.

## Presettings:

Pre-configuration	Setting
Operating mode	Monovalent
Heating circuit 1	Yes
Heating circuit 2	No
Passive cooling function	No
DHW preparation	Yes
DHW preparation request by	Sensor
Domestic hot water preparation flange heater	Yes
Swimming pool water preparation	No
Low-pressure brine	Display

## Legend:

1.	Heat Pump
1.1	Air-to-water heat pump
1.2	Brine-to-water heat pump
1.3	Water-to-water heat pump
1.4	Reversible air-to-water heat pump
1.5	Reversible brine-to-water heat pump
1.6	Reversible water-to-water heat pump
2.	Heat pump manager
3.	Parallel buffer tank
3.1	Buffer tank
4.	Hot water cylinder
5.	Swimming pool heat exchanger
6.	Passive cooling station with cooling controller N6
7.	Heating and silent or dynamic cooling
8.	Fan convector with 4-wire connection
9.	Cooling circuit only
10.	Heating circuit only
13.	Heat source
15.	Hydraulic tower
16.	Scalding protection
17.	Hydro tower HWK 332

### Domestic hot water distribution system:

DDV 32	Dual differential pressureless manifold (up to 2.5 m <sup>3</sup> /h)*
EB KPV	Extension module for compact manifold (up to 2.0 m <sup>3</sup> /h)*
KPV 25	Compact manifold with overflow valve (up to 1.3 m <sup>3</sup> /h)* In combination with EB KPV (up to 2.0 m <sup>3</sup> /h)*
MMB 25	Mixer module, bivalent (up to 2.0 m <sup>3</sup> /h)*
MMH 25	Mixer module for heating circuit
VTB 25	Manifold bar (up to 2.5 m <sup>3</sup> /h)*
WWM 25	Hot water module / unmixed heating circuit (up to 2.5 m <sup>3</sup> /h)*

\* Recommended max. heating waterflow

### Solarthermics:

SST 25	Solar station for hot water
SOLK 1204	Collector field
SOLPU 1	Solar station
SOLCU 1	Solar controller
SOLCU 2	Solar controller
T1	Temperature sensor (collector sensor)
T2	Temperature sensor (cylinder 1)
T3	Temperature sensor (cylinder 2 /optional display function)

B3	Hot water thermostat
B4	Swimming pool thermostat
E9	Flange heater, hot water
E10	2nd heat generator (HG2)
E10.1	Immersion heater
E10.2	Oil/gas boiler
E10.3	Solid fuel boiler
E10.5	Solar energy system
F7	Safety temperature monitor
K20	Contactora for 2nd heat generator
K21	Contactora for immersion heater hot water
M11	Primary pump for heating operation
M12	Primary pump for cooling operation
M13	Heat circulating pump for main circuit
M14	Heat circulating pump for heating circuit 1
M15	Heat circulating pump for heating circuit 2
M16	Auxiliary circulating pump
M17	Cooling circulating pump
M18	Hot water circulating pump
M19	Swimming pool water circulating pump
M21	Mixer
N1	Heating controller
N2	Cooling controller for reversible heat pumps
N3/N4	Room climate control stations
N6	Cooling controller for passive cooling
N12	Solar controller
R1	External wall sensor
R2/2.1	Return flow sensor
R3	Hot water sensor
R4	Return flow sensor for cooling water
R5	Temperature sensor for heating circuit 2
R9	Flow sensor (antifreeze)
R11	Flow sensor for cooling water
R13	Sensor for heating circuit 3 / bivalent-renewable
SMF	Dirt trap
TC	Room temperature controller
Y5	Three-way distribution valve
Y6	Two-way valve
Y7	Three-way mixing valve
Y8	Three-way valve (closing time max. 10 sec.)
Y12	External 4-way reversing valve